













CADEL















Il calore al centro

Features

Tecnologia / Technology / Technologie / Technologie

	Uscita concentrica integrata Integrated concentric outlet Sortie concentrique intégrée Integrierter konzentrischer Auslass (80 - 130 mm)		Kit concentrico (opzionale) Concentric flue kit (optional) Kit de système concentrique (opt.) Kit für konzentrisches Ableitungssystem (optional)		Camera stagna Sealed chamber Chambre étanche Dichtes Verbrennungsraum
	Braciere in ghisa Cast iron burning pot Brasero en fonte Brennschale aus Gusseisen		Porta in ghisa Cast iron door Porte en fonte Gusseisentür		Interno in refratt. con aria 2ª comb. Refractory stone inner with 2nd combustion air / Intérieur réfractaire à apport d'air secondaire Feuerraum aus Schamotte mit Sekundärluftverbrennung
	Interno in ghisa con aria 2ª combustione / Cast iron inner with 2nd combustion air / Intérieur fonte à apport d'air secondaire Feuerraum aus Gusseisen mit Sekundärluftverbrennung		Magic Glass		Shield
	Vista sul forno View on the oven Vue sur le four Sicht des Backofens		Cucinare Cooking Cuisiner Kochen		























Modalità d'uso / Conditions of use / Mode d'emploi / Gebrauchsanweisungen

	Wi-Fi integrato Integrated Wi-Fi Wi-Fi intégré Integriertes WIFI		Bluetooth integrato Integrated Bluetooth Bluetooth intégré Integriertes Bluetooth		Comfort mode
	Ventilazione + luce (opzionale) Ventilation + light kit (optional) Ventilation + éclairage (optionnel) Lüftung kit + Beleuchtung (optional)		Kit completo Idro riscaldamento + acqua sanitaria / Complete kit heating + domestic water Kit complet Idro chauffage + eau sanitaire Komplett-Set Hydro Heizung + Brauchwasser		Programmazione giornaliera settimanale / Daily weekly programming / Programmation journalière hebdomadaire Programmierung Tag - Woche
	Sensore di temperatura aria Air temperature sensor Capteur de température de l'air Temperaturfühler		Sensore di temperatura acqua Water temperature sensor Capteur de température de l'eau Wassertemperaturfühler		Collegamento termostato esterno Connection to the external thermostat Liaison thermostat externe Anschluss zu Außenthermostat
	Kit canalizzazione (opzionale) Ducting kit (optional) Kit conduits de canalisation (opt.) Kit für Kanalisierung (optional)		Canaliz. 1 motore indipendente Duction with 1 independ. motor Conduits d'aération avec 1 moteur indépendant / Kanalisierung mit 1 unabhängigen Luftgebläse		Canaliz. 2 motori indipendenti Duction with 2 independ. motors Conduits d'aération avec 2 moteurs indépendants / Kanalisierung mit 2 unabhängigen Luftgebläsen
	Collegamento all'impianto di riscaldamento / Connection to the heating system / Raccordement avec installation de chauffage Anschluss zu Heizungssystem		Kit idraulico incluso Hydraulic kit included Kit hydraulique inclus Hydrauliksatzen enthalten		Telecomando (opzionale) Remote control (optional) Télécommande (opt.) Fernbedienung (optional)

Modalità d'installazione / Installation mode / Mode d'installation / Einbaubedingungen

	Scarico fumi superiore, posteriore e laterale / Upper, back and lateral exhaust / Sortie fumée supérieure, postérieure et latérale Abgasstutzen Hinten, Seitlich, Oben		Scarico fumi superiore e posteriore Upper and back exhaust Sortie fumée supérieure et postérieure Abgasstutzen Hinten u. Oben		Scarico fumi superiore Upper exhaust Sortie fumée supérieure Abgasstutzen Oben
	Scarico fumi posteriore Back exhaust Sortie fumée postérieure Abgasstutzen Hinten		Scarico fumi laterale Lateral exhaust Sortie fumée latérale Abgasstutzen Seitlich		Canalizzazione superiore e posteriore Top and rear ducting Canalisation supérieure et arrière Obere und hintere Kanalisierung
	Built-in		Free Standing		

Technical data

	Potenza nominale Nominal power Puissance nominale Nennleistung		Potenza al focolare Heating input Puissance thermique globale Gesamtwärmeleistung		Potenza ridotta Reduced power Puissance réduite Verminderte Leistung
	Volume riscaldabile min/max Heatable volume min/max Volume à chauffer min/max Raumheizvermögen min/max		Capacità serbatoio Hopper capacity Capacité de réservoir Inhalt Pelletbehälter		
	Potenza utile all'acqua nominale Nominal useful water power Puissance utile à l'eau nominale Nennwärmeleistung - Wasseranteil		Potenza utile all'acqua ridotta Reduced useful water power Puissance utile à l'eau réduite Min Nennwärmeleistung Wasseranteil		
	Rendimento nominale Nominal performance Rendement nominal Wirkungsgrad bei Nennleistung		Rendimento ridotto Reduced performance Rendement réduit Wirkungsgrad bei verminderter Leistung		
	Consumo orario min/max Hourly consumption min/max Consommation horaire min/max Verbrauch pro Stunde		Autonomia min/max Range min/max Autonomie min/max Autonomie min/max		
	Combustibile pellet Pellet fuel Combustible granulés Brennstoff Pellet		Combustibile legna Wood fuel Combustible bois Brennstoff Holz		
	Scarico fumi Exhaust fumes Tuyau d'évacuation Rauchabzug		Presa aria comburente Hole combustion air inlet Prise d'air comburant Öffnungen für die Verbrennungsluft		Uscita canalizzazione Ducting outlet Canalisation Kanalauslass
	Misure imballo Packing dimensions Volume mesures Verpackung Ausmaße		Volume imballo Packing volume Volume emballage Verpackungsvolumen		Peso netto Net weight Poids net Nettogewicht
	Misure forno Oven dimensions Mesures four Backofenmaße		Misure bocca fuoco Fire box dimensions Mesures entree foyer Feuerstellemaße		
	Altezza piano Cooktop height Hauteur plan de cuisson Kochfeldshöhe				

Pellet Air

Spirit 5 ● 5,2 kW P. 12/70 	Sound 5 Up ● 5,5 kW P. 14/71 	Sound 7 Up ● 7 kW P. 14/71 	Grace 7 ● 7 kW P. 16/72 
--	--	--	--

Cristal 7 ● 7 kW P. 18/72 	Cristal 7 Up ● 7 kW P. 18/73 	Sweet 7 ● 7 kW P. 20/73 	Perla 7 ● 7 kW P. 22/74 	Kriss 9 ● 8,6 kW P. 24/74 	Cristal 9 ● 8,6 kW P. 26/75 
---	--	---	---	---	---

Quasimodo 9 Up ● 9,3 kW P. 28/75 	Zefiro 9 ● 9,3 kW P. 30/76 	Frame 9 ● 9,3 kW P. 32/76 	Frame 9 Up ● 9,3 kW P. 32/77 
--	--	---	---

Shell 9 Up ● 9,1 kW P. 34/77 	Shell 9 Ps ● 9,1 kW P. 34/78 	Sfera 11 ● 11 kW P. 36/78 	Prince 11 ● 11 kW P. 38/79 
--	--	---	--

Pellet Air Plus

Tile Plus 10 ● 10 kW P. 40/80 	Wall Plus 10 ● 10 kW P. 42/81 	Sfera Plus 11 ● 11 kW P. 44/81 	Prince Plus 11 ● 11 kW P. 46/82 
---	---	--	--

Atena Plus 12 ● 12 kW P. 48/82 	Atena Plus 14 ● 14 kW P. 48/83 	Mithos Plus 12 ● 12 kW P. 50/83 	Mithos Plus 14 ● 14 kW P. 50/84 
--	--	---	---

Pellet Hydro

Idro Prince 12 ● 11,8 kW P. 52/85 	Idro Prince 16 ● 16,2 kW P. 54/86 	Idro Prince 23/23 H₂O ● 22,8 kW P. 54/86 	Idro River 16 ● 16,2 kW P. 56/87 
---	---	---	---

Idro River 23/23 H₂O ● 22,8 kW P. 56/87 	Saturno 16 ● 18 kW P. 58/88 	Saturno 24 ● 24,7 kW P. 58/88 	Maya 16 ● 16,2 kW P. 60/89 	Maya 24 ● 22,8 kW P. 60/89 	Idro Prince 30 ● 28,6 kW P. 62/90 
--	---	---	--	--	---

Wood

Smart 60 ● 6,2 kW P. 64/91 	Smart 80 ● 7,5 kW P. 64/92 	Kook 60 4.0 ● 6,2 kW P. 66/92 	Kook 70 4.0 ● 6,2 kW P. 66/93 
--	--	---	--

Kook 80 4.0 ● 7,5 kW P. 66/93 	Kook 90 4.0 ● 7,5 kW P. 66/94 	Kook 67 ● 6,2 kW P. 66/94 	Kook 87 ● 7,5 kW P. 66/95 
---	---	---	---

Pellet Air

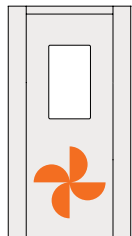

Cadel offre una gamma completa di stufe a pellet ad aria ventilata dotate di camera stagna per un maggior rendimento e minor consumo. Tutti i modelli di stufe Pellet Air sono certificati Classe Energetica A+, 4 stelle Aria Pulita, 7 stelle Flamme Verte e sono riconosciuti come idonei a ricevere il rimborso Conto Termico.

Cadel offers a comprehensive range of ventilated air pellet stoves with a sealed chamber for greater efficiency and reduced consumption. All Pellet Air Stove models are conform with the EcoDesign 2022 directives.

Cadel propose une gamme complète de poêles à pellets à air ventilé équipés d'une chambre étanche pour un meilleur rendement et une moindre consommation. Tous les modèles de poeles Pellet Air sont certifiés 7 étoiles Flamme Vert et sont reconnus comme éligibles au crédit d'impôt. En outre, un an après leur introduction, ils sont référencés CSTB.

Cadel bietet eine vollständige Palette von Pelletöfen mit Gebläse und abgedichteter Brennkammer zur Gewährleistung von höherer Leistung und geringerem Verbrauch. Alle Pelletöfen_Modelle der Linie Air sind Bimsch 2015 (Regensburg, München, Stuttgart, Aachen) und Klima Energiefonds zertifiziert.

Pellet Air Plus

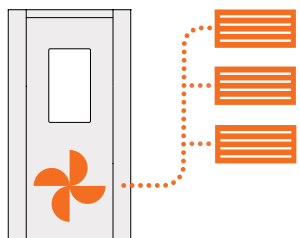

Per riscaldare più ambienti della casa in modo economico e pratico la stufa a pellet canalizzabile Air Plus di Cadel è lo strumento ideale. Grazie al sistema di canalizzazione è possibile distribuire il calore rapidamente e in modo omogeneo anche in altre stanze. Tutti i modelli di stufe Pellet Air Plus sono certificati Classe Energetica A+, 4 stelle Aria Pulita, 7 stelle Flamme Verte e sono riconosciuti come idonei a ricevere il rimborso Conto Termico.

A Cadel Air Plus ductable pellet stove is the ideal tool to heat up several rooms in the house in a cost-effective and convenient way. Thanks to its ducting, you can distribute heat quickly and evenly in other rooms as well. All Pellet Air Plus Stove models are conform with the EcoDesign 2022 directives.

Pour chauffer plusieurs pièces de la maison de manière économique et pratique, le poêle à pellets canalisable Air Plus de Cadel est l'instrument idéal. Grâce au système de canalisation, il est possible de distribuer la chaleur rapidement et de façon homogène dans d'autres pièces aussi. Tous les modèles de poeles Pellet Air plus sont certifiés 7 étoiles Flamme Vert et sont reconnus comme éligibles au crédit d'impôt. En outre, un an après leur introduction, ils sont référencés CSTB.

Der kanalisierbare Pellet ofen Air Plus von Cadel ist die ideale Lösung, um auf sparsame und praktische Weise mehrere Wohnräume zu erwärmen. Die Kanalisierung ermöglicht es, die Wärme rasch und gleichmäßig auch auf andere Räume zu verteilen. Alle Pelletöfen_Modelle der Linie Air Plus sind Bimsch 2015 (Regensburg, München, Stuttgart, Aachen) und Klima Energiefonds zertifiziert.

Pellet Hydro

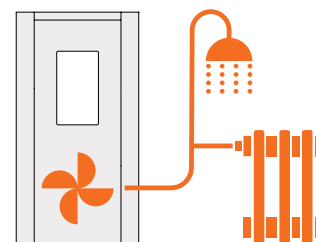

Le termostufe Cadel sono la soluzione ottimale per l'impianto di riscaldamento domestico, riscaldando rapidamente l'acqua dei termosifoni, sono pratiche ed economiche ed uniscono la funzionalità ad un'estetica accattivante. Alcuni modelli sono disponibili nella versione H₂O: dotate di un apposito kit queste termostufe a pellet possono produrre acqua calda sanitaria.

Cadel thermostoves are an excellent solution for domestic heating systems, since they quickly heat water in the radiators, they are convenient and cost-effective, and combine functionality with a charming design. Some models are available in the H₂O version: equipped with a special kit, these pellet thermostoves can produce domestic hot water.

Les thermo-poêles Cadel sont une excellente solution pour le chauffage domestique, car ils chauffent rapidement l'eau des radiateurs, ils sont pratiques et économiques et allient fonctionnalité et aspect attrayant. Certains modèles sont disponibles dans la version H₂O : équipés d'un kit spécial, ces thermo-poêles à pellets peuvent produire de l'eau chaude sanitaire.

Die Thermoöfen von Cadel sind eine optimale Lösung für Wohnungsheizanlagen. Sie sorgen für eine schnelle Erwärmung des Wassers in den Heizkörpern, sind praktisch und wirtschaftlich und verbinden Funktionalität mit attraktiver Ästhetik. Einige Modelle sind auch in der Version H₂O erhältlich: Mit einem speziellen Bausatz ausgestattet können diese Pelletöfen auch das Warmwasser liefern.

Wood

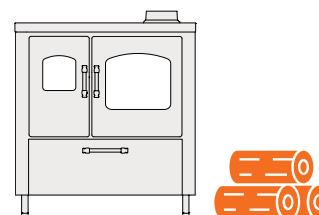

Conformi alle normative ambientali più severe, i prodotti a legna Cadel a libera installazione e da incasso uniscono il riscaldamento domestico, la versatilità installativa e l'estetica elegante. Grazie ad attente soluzioni costruttive, questi prodotti non necessitano di ulteriori kit per l'inserimento all'interno di un mobile cucina e le finiture curate permettono di poterle installare liberamente in qualsiasi ambiente.

Compliant with the strictest environmental regulations, Cadel's free and recessed installation wood products combine home heating with versatile installation and elegant aesthetics. Thanks to meticulous construction solutions, these products do not require additional kits for insertion in kitchen units and are well finished, which allows them to be easily installed in any room.

En conformité avec les réglementations environnementales les plus strictes, les produits à bois Cadel autonomes et encastrables allient le chauffage domestique, la polyvalence d'installation et l'esthétique élégante. Grâce à des solutions de construction soignées, ces produits ne nécessitent pas de kits supplémentaires pour l'insertion dans un meuble de cuisine, et les finitions raffinées permettent de les installer librement dans n'importe quelle pièce.

Die Holzgefeuerten Geräte von Cadel zur freistehenden Installation und zum Einbau vereinen in sich das Heizen der Wohnung, die Flexibilität bei der Installation und ein elegantes Design. Dank ihrer besonderen Bauart ist bei diesen Geräten kein zusätzlicher Bausatz für den Einbau in eine Küchenzeile erforderlich, und durch die edlen Oberflächen ist die Installation freistehend in jedem beliebigen Raum möglich.

Il calore al centro



Storia di passione e innovazione.

Il calore al centro è il fondamento del progetto attorno al quale ruotano le proposte Cadel. Il piacere di stare insieme e di essere circondati dalle cose amate sono i valori in cui crediamo e intorno ai quali costruiamo le nostre stufe, valori garantiti dalla costante ricerca che svolgiamo con passione da oltre sessant'anni. Dal 1949 progettiamo e sviluppiamo i nostri prodotti in Italia per distribuirli in tutto il mondo, facendo forza sulla nostro Know-How, sulla nostra intuizione creativa e sull'utilizzo di tecnologie innovative, per ambienti sempre accoglienti e belli da vivere.

Cadel oggi significa:

Semplicità

Soluzioni dal design pulito, "senza tempo", facili nell'utilizzo, alla portata di tutti.

Affidabilità

Esperienza, ricerca e customer service sono la garanzia della serietà di Cadel e dei prodotti che durano nel tempo.

Convenienza

Progettare prodotti a un prezzo accessibile, senza compromettere la qualità.

● Our values

Focus on heat

A story of passion and innovation.

Heat is the focus of each project and the cornerstone around which Cadel's solutions take shape. To enjoy spending time together, surrounded by the things we love: these are the values we believe in and around which we build our stoves. We are able to guarantee these values through our ongoing research, which we have been conducting with great passion for over 60 years. We have been designing and developing our products in Italy and distributing them worldwide since 1949. We leverage our know-how, our creative intuition and cutting-edge technology, for spaces that are always cosy and wonderful to live in. Today, Cadel stands for:

Simplicity

Solutions with a clean and timeless design, easy to use and suitable for every pocket.

Reliability

Experience, research and customer service assure that Cadel is a reliable company offering long-lasting products.

Affordability

Designing products at an affordable price, without compromising on quality.

● Nos valeurs

La chaleur au centre

Une histoire de passion et innovation.

Quand on réalise un projet, la chaleur est le point de départ autour duquel toutes les idées que propose Cadel sont articulées. Le plaisir d'être ensemble et de s'entourer des objets bien-aimés sont des valeurs auxquelles nous croyons et autour desquelles nous construisons nos poêles, des valeurs garanties par la recherche constante que nous menons avec passion depuis plus de soixante ans. Depuis 1949, nous concevons et développons nos produits en Italie pour les distribuer dans le monde entier, en nous appuyant sur notre savoir-faire, notre intuition créative et l'utilisation de technologies innovantes, pour des environnements toujours accueillants et agréables à vivre. Aujourd'hui, Cadel est synonyme de :

Simplicité

Des solutions au design épuré, « intemporelles », faciles à utiliser, à la portée de tout le monde.

Fiabilité

L'expérience, la recherche et le client sont le gage du sérieux de Cadel et des produits qui durent au fil du temps.

Prix avantageux

Concevoir des produits à un prix abordable, sans compromis sur la qualité.

● Unsere Werte

Die Wärme im Mittelpunkt

Eine Geschichte aus Leidenschaft und Innovation.

Die Wärme im Mittelpunkt des Projekts ist die Basis, um die sich die Angebote von Cadel drehen. Die Freude am Zusammensein und an den schönen Dingen des Lebens sind die Werte, an die wir glauben, und damit auch die Grundlage für unsere Öfen. Diese Werte werden beständig von Forschungsarbeiten untermauert, die wir seit über sechzig Jahren mit Hingabe betreiben. Seit 1949 projektieren und entwickeln wir unsere Geräte in Italien, um sie dann in die ganze Welt zu verkaufen. Unsere Stärken sind unser Know-how, unsere kreative Intuition und die Verwendung innovativer Technologien für Räume, die immer einladend und gemütlich sind. Cadel bedeutet heute:

Schlichtheit

Lösungen mit klaren Linien, „zeitlos“, nutzerfreundlich und für jeden erschwinglich.

Zuverlässigkeit

Erfahrung, Forschung und Kundenservice sind die Garantie für die seriöse Vorgehensweise von Cadel und für Geräte mit langer Lebensdauer.

Günstige Preise

Die Entwicklung von bezahlbaren Geräten ohne Kompromisse bei der Qualität.



WiFi integrato

La connessione wifi consente la gestione locale e remota della stufa tramite la nuova ed intuitiva app **Easy Connect Plus** da qualunque luogo in cui ci troviamo. Basta avere uno smartphone o tablet e una connessione dati disponibile.

Built-in Wi-Fi

Wi-Fi connection allows you to control the stove both locally and remotely by using the new user-friendly **Easy Connect Plus** app from wherever you are. All you need is a smartphone or tablet with data connection.

Wi-Fi intégré

La connexion Wi-Fi permet de gérer le poêle localement et à distance grâce à la nouvelle application intuitive **Easy Connect Plus**, où que vous soyez. Il suffit d'avoir un smartphone ou une tablette et de disposer d'une connexion de données.

Integriertes WiFi

Die WiFi-Verbindung gestattet die Bedienung des Ofens vor Ort und aus der Ferne über die neue und intuitive App **Easy Connect Plus**: von jedem Ort, an dem Sie sich gerade befinden. Sie brauchen lediglich ein Smartphone oder Tablet und eine WiFi-Verbindung.



Comfort mode

Disattiva automaticamente i ventilatori della stufa riducendo la potenza al minimo, per garantire la massima silenziosità.

Comfort mode

This automatically Deactivates the stove fans, setting it on minimum power to guarantee maximum silence.

Mode Comfort

Les ventilateurs du poêle sont automatiquement désactivés et la puissance réduite au minimum, afin de garantir le maximum de silence.

Comfort Mode

Automatische Deaktivierung der Gebläse des Ofens und damit Reduzierung der Leistung auf ein Mindestmaß, um maximale Ruhe zu gewährleisten.

semplicità



Ventilatori indipendenti

Grazie al sistema di canalizzazione dell'aria, con le stufe Air Plus è possibile distribuire il calore in modo omogeneo in più stanze. A seconda delle esigenze abbiamo stufe canalizzabili a due o tre uscite: tutti i ventilatori di canalizzazione possono essere gestiti in modo autonomo.

Independent fans

Thanks to the air ducting system of the Air Plus stoves, heat can be evenly distributed in several rooms. Depending on your needs, we have ductable stoves with two or three outlets: all fans can be controlled separately.

Ventilateurs indépendants

Grâce au système de canalisation de l'air, les poêles Air Plus permettent de distribuer la chaleur de façon homogène dans plusieurs pièces. En fonction des besoins, il est possible d'opter pour un poêle canalisable à deux ou trois sorties : tous les ventilateurs peuvent être gérés de manière autonome.

Unabhängige Gebläse

Die Kanalisierung ermöglicht es bei den Air Plus Öfen, die Wärme rasch und gleichmäßig in mehreren Räumen zu verteilen. Je nach Bedarf bieten wir Öfen mit zwei oder drei Luftauslässen an: Hier können alle Gebläse unabhängig gesteuert werden.

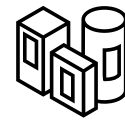

Ampiezza di gamma e versatilità scarico fumi

L'ampia gamma CADEL ti consentirà di scegliere la stufa che più si adatta ai tuoi spazi: slim, tonda o quadrata con la versatilità di uscita scarico fumi: superiore, posteriore, laterale e coassiale.

An extensive range and a versatile smoke outlet

Thanks to CADEL's extensive range of products, you can choose the stove that best suits your space: slim, round or square with a versatile smoke outlet: upper, back, lateral and coaxial.

Ampleur de la gamme et polyvalence de l'évacuation des fumées

La large gamme CADEL vous permettra de choisir le poêle qui convient le mieux à vos espaces : slim, rond ou carré avec la sortie d'évacuation des fumées qui s'adapte à tous les besoins : supérieure, arrière, latérale et coaxiale.

Breites Angebot

und Vielseitigkeit beim Rauchgasabzug Das große Angebot von CADEL gibt Ihnen die Möglichkeit, den Ofen auszuwählen, der für Ihre Räumlichkeiten am besten geeignet ist – slim, rund oder eckig – mit unterschiedlicher Position des Rauchgasabzugs: oben, hinten, seitlich oder koaxial.



Camera stagna

Stufe a pellet totalmente ermetiche rispetto all'ambiente d'installazione: prelevano l'aria di combustione dall'esterno e non dal locale in cui sono installate.

- Meno emissioni
- Più sicurezza
- Maggiore rendimento

Sealed chamber

Pellet stoves that are completely sealed in relation to the room of installation: they draw combustion air directly from outdoors and not from the room they are installed in.

- Fewer emissions
- More safety
- Greater efficiency

Chambre étanche

Ces poêles à pellets sont parfaitement hermétiques par rapport à l'environnement d'installation : ils prélèvent l'air de combustion de l'extérieur directement et non pas du local dans lequel ils sont installés.

- Moins d'émissions
- Plus de sécurité
- Meilleur rendement

Abgedichtete kammer

Vollkommen gegen die Installationsumgebung abgedichtet: Die Verbrennungsluft wird direkt von außen angesaugt, nicht aus dem Raum, in dem der Ofen installiert ist.

- Weniger Emissionen
- Mehr Sicherheit
- Höherer Wirkungsgrad

affidabilità



Innovazione e certificazioni

Prodotti certificati secondo le più stringenti normative europee. Tutta la gamma risponde ai requisiti Eco Design 2022.

Innovation and certifications

Products certified according to the most stringent European regulations. The entire range meets Eco Design 2022 requirements.

Innovation et certifications

Produits certifiés selon les normes européennes les plus strictes. L'ensemble de la gamme est conforme aux exigences Eco Design 2022.

Innovation und

Zertifizierungen Nach den strengsten europäischen Normen zertifizierte Geräte. Alle Geräte entsprechen den Anforderungen von Eco Design 2022.



Un nuovo cuore pulsa nelle stufe CADEL

Una innovativa caldaia composta da due gusci in acciaio alluminato, per una perfetta combustione del pellet.

- Maggiore scambio termico
- Maggiore rifrazione della fiamma
- Minori emissioni
- Minori consumi

A new beating heart of CADEL stoves

An innovative boiler composed of two aluminised steel shells inside of which perfect pellet combustion occurs.

- More surface area for thermal exchange
- Greater flame refraction
- Lower emissions
- Lower consumption

Un nouveau cœur bat dans les poêles CADEL

Une chaudière innovante composée de deux coques en acier aluminisé garanti à l'intérieure une combustion parfaite du pellet.

- Plus grande surface d'échange thermique
- Plus grande réfraction de la flamme
- Moins d'émissions
- Moindres consommations

In den Öfen von CADEL schlägt ein neues Herz

Ein innovativer Kessel, der aus zwei Schalen aus Aluminiumstahl besteht und in dem eine perfekte Verbrennung der Pellets erfolgt.

- Größere Wärmeaustauschfläche
- Bessere Lichtbrechung
- Weniger Emissionen
- Geringerer Verbrauch

convenienza



Rapporto qualità prezzo

L'ampia gamma CADEL consentirà di scegliere la stufa che più si adatta alle esigenze del consumatore.

Rapport qualité-prix

La large gamme CADEL permet de choisir le poêle qui répond le mieux aux besoins du consommateur.

Value for money

Thanks to CADEL's extensive range of products, consumers can choose the stove that best suits their needs.

Preis-Leistungs-Verhältnis

Das große Angebot von CADEL ermöglicht die Wahl des Ofens, der am besten zu den Anforderungen des Verbrauchers passt.

● WiFi & Bluetooth

Easy Connect Plus



Per una stufa sempre connessa e intelligente

Con la nuova app **Easy Connect Plus**, e le tecnologie **WiFi e Bluetooth** integrate, puoi accendere, programmare, controllare e spegnere tutte le stufe CADEL direttamente dal tuo smartphone, ovunque tu sia. In una sola schermata puoi controllare e gestire le funzioni principali, impostando tempi e temperatura desiderata per ottimizzare i consumi e migliorare il comfort.

For a smart stove connected at all times

Thanks to the new **Easy Connect Plus** app, and the built-in **Wi-Fi** and **Bluetooth** technologies, you can turn on, set up, control and turn off all CADEL stoves easily using your smartphone – wherever you are. From a single screen, you can access and control the main features and set on/off times and the desired temperature for optimal consumption and greater comfort.

Pour un poêle toujours connecté et intelligent

Grâce à la nouvelle application **Easy Connect Plus** et aux technologies **Wi-Fi** et **Bluetooth** intégrées, vous pouvez allumer, programmer, contrôler et éteindre tous les poêles CADEL depuis votre smartphone, où que vous soyez. Une seule page vous permet de contrôler et gérer les fonctions principales, régler les durées et la température souhaitée, afin d'optimiser les consommations et améliorer le confort.

Für einen stets verbundenen und intelligenten Ofen

Mit der neuen App **Easy Connect Plus** und den integrierten **WLAN** – und **Bluetooth** – Technologien können Sie alle Öfen von CADEL direkt von Ihrem Smartphone aus einschalten, programmieren, steuern und ausschalten, wo immer Sie sich gerade befinden. Von einer einzigen Ansicht aus können Sie die wichtigsten Funktionen steuern und verwalten und die Betriebszeiten und die gewünschte Temperatur einstellen. So können Sie den Verbrauch optimieren und den Wärmekomfort nach Ihren Wünschen gestalten.



Informazioni

Una panoramica sullo stato di funzionamento della stufa, in relazione alle funzioni e regolazioni attive.

Information

An overview of the stove's operating status in relation to active functions and adjustments.

Informations

Un aperçu de l'état de fonctionnement du poêle, en ce qui concerne les fonctions et réglages activés.

Informationen

Eine Übersicht über den Betriebsstatus des Ofens je nach den aktivierten Funktionen und Regulierungen.



Regolazioni

Regolazione potenza, temperatura ambiente, canalizzazione, ventilazione e Eco Stop. Nelle stufe idro controllo della temperatura dell'acqua per Caldaia e Puffer.

Adjustments

Power, room temperature, ducting, ventilation and Eco Stop adjustment. Boiler and Puffer water temperature can be controlled in hydro stoves.

Réglages

Réglage de la puissance, de la température ambiante, des canalisations, de la ventilation et de la fonction Eco Stop. Contrôle de la température de l'eau de la chaudière et du ballon tampon des poêles hydro.

Regulierungen

Regulierung der Leistung, der Raumtemperatur, der Luftkanalisierung und der Ventilation sowie Eco Stop. Bei den wasserführenden Öfen Temperaturkontrolle von Kessel und Pufferspeicher.

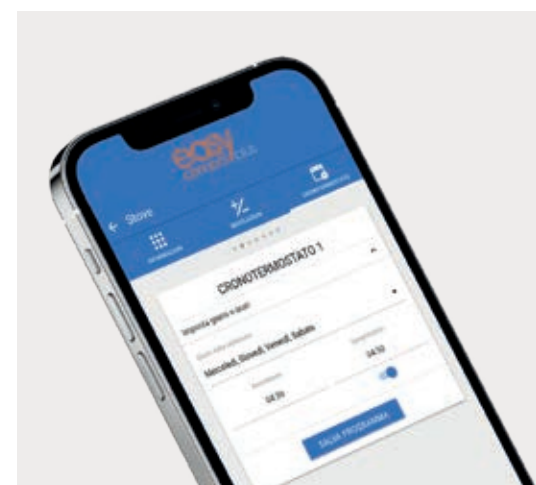

Cronotermostato

Programmazione per l'accensione e lo spegnimento della stufa in base alle esigenze di comfort.

Programmable thermostat

Programme the stove to switch on or off as needed for your comfort.

Thermostat programmable

Programmation pour allumer et éteindre le poêle en fonction des besoins de confort.

Zeitthermostat

Programmierung zum Ein- und Ausschalten des Ofens je nach gewünschtem Wärmekomfort.



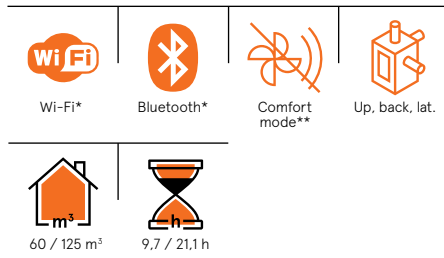

***Gestione tramite Wi-Fi e Bluetooth integrati**
Control through integrated Wi-Fi and Bluetooth
Gestion via Wi-Fi et Bluetooth intégré
Verwaltung über WiFi und integriertes Bluetooth

****Disattiva i ventilatori per garantire la massima silenziosità**
Deactivates stove fans, to guarantee maximum silence / Désactivés les ventilateurs afin de garantir le maximum de silence / Deaktivierung der Gebläse, um maximale Ruhe zu gewährleisten

5,2 kW



Spirit 5

- **Forme snelle e compatte dal design moderno**
- **Porta e braciere in ghisa**
- **Scarico fumi superiore, posteriore o laterale**



- Slim and compact shapes with a modern design
- Cast iron door and burning pot
- Upper, back or lateral exhaust

- Formes élancées et compactes au design moderne
- Porte et brasier en fonte
- Évacuation des fumées supérieure, arrière ou latérale.

- Schlanke und kompakte Formen mit modernem Design
- Tür und Brennschale aus Gusseisen
- Rauchgasabzug oben, hinten oder seitlich



Wi-Fi*



Bluetooth*



Magic glass**



Up

***Gestione tramite Wi-Fi e Bluetooth integrati**
Control through integrated Wi-Fi and Bluetooth
Gestion via Wi-Fi et Bluetooth intégré
Verwaltung über WiFi und integriertes Bluetooth

****Vetro oscurato Magic Glass a stufa spenta**
Magic Glass tinted glass when the stove is off
Vitre obscurcie Magic Glass lorsque le poêle est éteint
Getönte Magic Glas Glasscheibe bei ausgeschaltetem Ofen

5,2/
7 kW



55 / 132 m³ (5 Kw)
55 / 168 m³ (7 Kw)



- Round shape with Magic Glass
- Cast iron top and base
- Concentric top outlet

- Forme ronde avec vitre Magic Glass
- Couvercle et base en fonte
- Sortie supérieure concentrique

- Runde Form mit Magic Glass Glasscheibe
- Topplatte und Sockel aus Gusseisen
- Konzentrischer Rauchgasabzug oben

Sound 5/7 Up

- Forma tonda con Vetro Magic Glass
- Top e base in ghisa
- Uscita superiore concentrica





Wi-Fi*



Bluetooth*



Comfort mode**



Up, back, lat.

***Gestione tramite Wi-Fi e Bluetooth integrati**
Control through integrated Wi-Fi and Bluetooth
Gestion via Wi-Fi et Bluetooth intégré
Verwaltung über WiFi und integriertes Bluetooth

****Disattiva i ventilatori per garantire la massima silenziosità**
Deactivates stove fans, to guarantee maximum silence / Désactivés les ventilateurs afin de garantir le maximum de silence / Deaktivierung der Gebläse, um maximale Ruhe zu gewährleisten

7 kW



65 / 168 m²



- Elegant and contemporary design
- Only 27.5 cm deep, for confined spaces
- Possibility of wall or suspended installation

- Design élégant et contemporain
- Seulement 27,5 cm de profondeur dans les petits espaces
- Possibilité d'installation murale ou suspendue









- Elegantes und zeitgenössisches Design
- Nur 27,5 cm Tiefe, für enge Platzverhältnisse
- Möglichkeit der Installation an der Wand oder hängend

Grace 7



- Design elegante e contemporaneo
- Soli 27,5 cm di profondità, per gli spazi ristretti
- Possibilità di installazione a parete o sospesa



 Wi-Fi*	 Bluetooth*	 Comfort mode**	 Back
 Up	 55 / 168 m ³	 7.1 / 20 h (Up) 8.8 / 25 h	 12 kg (Up) 15 kg

***Gestione tramite Wi-Fi e Bluetooth integrati**
Control through integrated Wi-Fi and Bluetooth
Gestion via Wi-Fi et Bluetooth intégré

****Disattiva i ventilatori per garantire la massima silenziosità**
Deactivates stove fans, to guarantee maximum silence / Désactivés les ventilateurs afin de garantir le maximum de silence / Deaktivierung der Gebläse, um maximale Ruhe zu gewährleisten

7 kW



- New model with upper exhaust
- Great value for money
- Wi-Fi and Bluetooth included

- Nouveau modèle avec évacuation par le haut
- Excellent rapport qualité-prix
- Wi-Fi et Bluetooth inclus

- Neues Modell mit Rauchgasabzug oben
- Ausgezeichnetes Preis-Leistungs-Verhältnis
- Wifi und Bluetooth inbegriffen

Cristal 7/7 Up

- Nuovo modello con scarico superiore
- Ottimo rapporto qualità prezzo
- Wifi e bluetooth incluso



Cristal 7



Wi-Fi*



Bluetooth*



Comfort mode**



Back

***Gestione tramite Wi-Fi e Bluetooth integrati**
Control through integrated Wi-Fi and Bluetooth
Gestion via Wi-Fi et Bluetooth intégré
Verwaltung über WiFi und integriertes Bluetooth

****Disattiva i ventilatori per garantire la massima silenziosità**
Deactivates stove fans, to guarantee maximum silence / Désactivés les ventilateurs afin de garantir le maximum de silence / Deaktivierung der Gebläse, um maximale Ruhe zu gewährleisten

7 kW



55 / 168 m²



15 kg

Sweet 7

- **Forme semplici con rivestimenti in metallo in 3 colori**
- **Elevato rendimento**
- **Semplicità d'uso con display di controllo e wifi incluso**

- Simple shapes with metal cladding in 3 colours
- High efficiency
- Easy to use with control display and Wi-Fi included
- Formes simples et revêtements en métal de 3 couleurs
- Rendement élevé
- Simplicité d'utilisation avec écran de commande et Wi-Fi inclus
- Schlichte Formen mit Metallverkleidung in 3 Farben
- Hohe Leistung
- Einfache Nutzung mit Bediendisplay und inbegriffenem WiFi





Wi-Fi*



Bluetooth*



Comfort mode**



Back

***Gestione tramite Wi-Fi e Bluetooth integrati**
Control through integrated Wi-Fi and Bluetooth
Gestion via Wi-Fi et Bluetooth intégré
Verwaltung über WiFi und integriertes Bluetooth

****Disattiva i ventilatori per garantire la massima silenziosità**
Deactivates stove fans, to guarantee maximum silence / Désactivés les ventilateurs afin de garantir le maximum de silence / Deaktivierung der Gebläse, um maximale Ruhe zu gewährleisten

7 kW



55 / 168 m³



15 kg



Consumer 2021



New



- Top e braciara in ghisa
- Ampia gamma di rivestimenti in acciaio
- Rivestimenti pregiati in ceramica

- Cast iron top and burning pot
- Wide range of steel cladding
- High-quality ceramic cladding

- Couvercle et brasier en fonte
- Large gamme de revêtements en acier
- Revêtements précieux en céramique

- Topplatte und Brennschale aus Gusseisen
- Große Palette an Verkleidungen aus Stahl
- Edle Verkleidungen aus Keramik

→ Technical data P. 74

Pellet Air

23

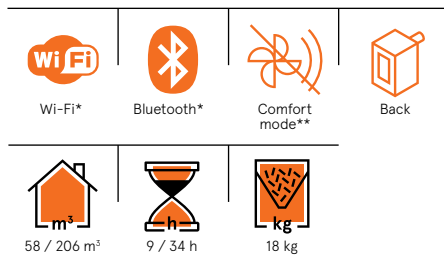

***Gestione tramite Wi-Fi e Bluetooth integrati**
Control through integrated Wi-Fi and Bluetooth
Gestion via Wi-Fi et Bluetooth intégré
Verwaltung über WiFi und integriertes Bluetooth

****Disattiva i ventilatori per garantire la massima silenziosità**
Deactivates stove fans, to guarantee maximum silence / Désactivés les ventilateurs afin de garantir le maximum de silence / Deaktivierung der Gebläse, um maximale Ruhe zu gewährleisten

8,6 kW

- Simple and original design
- Large view of the fire
- Wide choice of colours for metal cladding

- Lignes simples et originales
- Grande vue du feu
- Vaste choix de couleurs pour les revêtements métalliques

- Schlichte und originelle Linien
- Gute Sicht auf das Feuer
- Große farbliche Auswahl bei den Verkleidungen aus Metall



Kriss 9



- Linee semplici e originali
- Ampia visione del fuoco
- Ampia scelta cromatica per i rivestimenti metallici



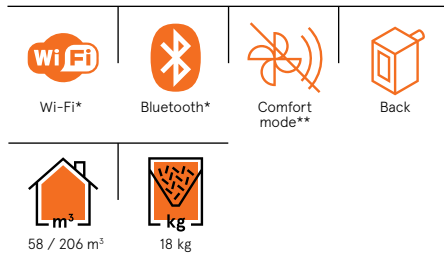

***Gestione tramite Wi-Fi e Bluetooth integrati**
Control through integrated Wi-Fi and Bluetooth
Gestion via Wi-Fi et Bluetooth intégré
Verwaltung über WiFi und integriertes Bluetooth

****Disattiva i ventilatori per garantire la massima silenziosità**
Deactivates stove fans, to guarantee maximum silence / Désactivés les ventilateurs afin de garantir le maximum de silence / Deaktivierung der Gebläse, um maximale Ruhe zu gewährleisten

8,6 kW



- Great value for money
- Functional with built-in Wi-Fi and Bluetooth
- Extensive choice of side cladding finishes

- Excellent rapport qualité-prix
- Fonctionnel grâce au Wi-Fi et au Bluetooth intégrés
- Large choix de finitions pour les revêtements latéraux

- Ausgezeichnetes Preis-Leistungs-Verhältnis
- Funktional mit integriertem WiFi und Bluetooth
- Große Auswahl an Oberflächen bei den Seitenverkleidungen

Cristal 9



- **Ottimo rapporto qualità prezzo**
- **Funzionale con wifi e bluetooth integrato**
- **Ampia scelta di finiture per rivestimenti laterali**





Wi-Fi*



Bluetooth*



Comfort mode**



Up

***Gestione tramite Wi-Fi e Bluetooth integrati**
Control through integrated Wi-Fi and Bluetooth
Gestion via Wi-Fi et Bluetooth intégré
Verwaltung über WiFi und integriertes Bluetooth

****Disattiva i ventilatori per garantire la massima silenziosità**
Deactivates stove fans, to guarantee maximum silence / Désactivés les ventilateurs afin de garantir le maximum de silence / Deaktivierung der Gebläse, um maximale Ruhe zu gewährleisten

9,3 kW



65 / 223 m²

Quasimodo 9 Up



- Simple shapes for a design that furnishes
- Airtight and powerful with glass door and cast-iron firebox
- Upper smoke outlet

- Formes essentielles pour un design qui meuble
- Hermétique et puissant avec porte en verre et foyer en fonte
- Sortie des fumées par le haut

- Schlichte Formen und wohnliches Design
- Hermetisch und leistungsstark mit Glastür und Brennkammer aus Gusseisen
- Rauchabzug oben

- **Forme essenziali per un design che arreda**
- **Ermetica e potente con porta in vetro e focolare in ghisa**
- **Uscita fumi superiore**



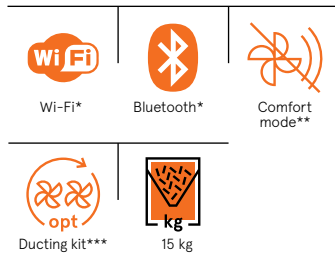

***Gestione tramite Wi-Fi e Bluetooth integrati**
Control through integrated Wi-Fi and Bluetooth
Gestion via Wi-Fi et Bluetooth intégré
Verwaltung über WiFi und integriertes Bluetooth

****Disattiva i ventilatori per garantire la massima silenziosità**
Deactivates stove fans, to guarantee maximum silence / Désactivés les ventilateurs afin de

garantir le maximum de silence / Deaktivierung der Gebläse, um maximale Ruhe zu gewährleisten

*****Kit canalizzazione (opzionale)**
Ducting kit (optional)
Kit conduits de canalisation (opt.)
Kit für Kanalisierung (optional)

9,3 kW



- Large glass window for a better view of the flame
- It integrates perfectly into open fireplaces
- Ducting available with optional kit
- Grande vitre pour une meilleure vue des flammes
- Intégration parfaite dans les cheminées ouvertes
- Solutions de canalisation avec kit en option
- Große Glasscheibe für mehr Sicht auf das Feuer
- Passt genau in offene Kamine
- Möglichkeit der Luftkanalisierung durch optionales Zubehörset

Zefiro 9



- Ampio vetro per una maggiore visione della fiamma
- Si integra perfettamente nei camini aperti
- Possibilità di canalizzazione con Kit opzionale

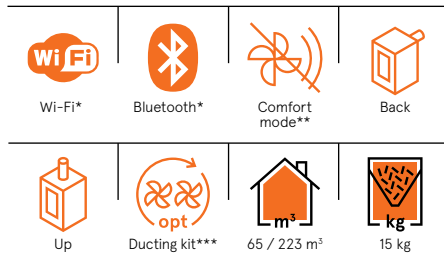

***Gestione tramite Wi-Fi e Bluetooth integrati**
Control through integrated Wi-Fi and Bluetooth
Gestion via Wi-Fi et Bluetooth intégré

garantir le maximum de silence / Deaktivierung der Gebläse, um maximale Ruhe zu gewährleisten

*****Kit canalizzazione (opzionale)**
Ducting kit (optional)
Kit conduits de canalisation (opt.)
Kit für Kanalisierung (optional)

****Disattiva i ventilatori per garantire la massima silenziosità**
Deactivates stove fans, to guarantee maximum silence / Désactivés les ventilateurs afin de

9,3 kW

- Sophisticated and metropolitan
- Large glass window to enjoy the heat of the flame
- Ducting available with optional kit

- Élégant et métropolitain
- Large vitre pour profiter au mieux de la chaleur de la flamme
- Solutions de canalisation avec kit en option

- Raffiniert und zeitgenössisch
- Große Glasscheibe zum Genießen des Feuers
- Möglichkeit der Luftkanalisierung durch optionales Zubehörsset

Frame 9 Frame 9 Up



- Raffinata e metropolitana
- Vetro ampio per apprezzare il calore della fiamma
- Possibilità di canalizzazione con Kit opzionale



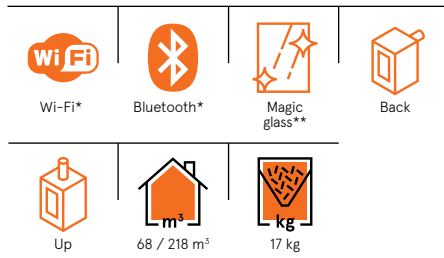

***Gestione tramite Wi-Fi e Bluetooth integrati**
Control through integrated Wi-Fi and Bluetooth
Gestion via Wi-Fi et Bluetooth intégré
Verwaltung über WiFi und integriertes Bluetooth

****Vetro oscurato Magic Glass a stufa spenta**
Magic Glass tinted glass when the stove is off
Vitre obscurcie Magic Glass lorsque le poêle est éteint
Getönte Magic Glas Glasscheibe bei ausgeschaltetem Ofen

9,1 kW



Shell 9 Up/Ps



- Linee morbide e materiali high tech
- Vetro oscurato Magic Glass a stufa spenta
- Scarico fumi posteriore o superiore

- Soft lines and high-tech materials
- Magic Glass tinted glass when the stove is off
- Upper or back exhaust

- Lignes souples et matériaux high tech
- Vitre obscurcie Magic Glass lorsque le poêle est éteint
- Évacuation des fumées arrière ou supérieure

- Weiche Linien und High-Tech-Materialien
- Getönte Magic Glas Glasscheibe bei ausgeschaltetem Ofen
- Rauchgasabzug hinten oder oben



Wi-Fi*



Bluetooth*



Comfort mode**



Lat.

***Gestione tramite Wi-Fi e Bluetooth integrati**
Control through integrated Wi-Fi and Bluetooth
Gestion via Wi-Fi et Bluetooth intégré
Verwaltung über WiFi und integriertes Bluetooth

****Disattiva i ventilatori per garantire la massima silenziosità**
Deactivates stove fans, to guarantee maximum silence / Désactivés les ventilateurs afin de garantir le maximum de silence / Deaktivierung der Gebläse, um maximale Ruhe zu gewährleisten

11 kW



79 / 264 m³



22 kg

BISTROT
PIANO 01



Sfera 11

- **Semplice ed essenziale**
- **Adatta per il posizionamento ad angolo**
- **Display sul top per le regolazioni di base e wifi integrato**



- Simple and minimalist
- Suitable for corner installation
- Display on top for basic adjustments and built-in Wi-Fi

- Simple et essentiel
- Indiqué pour la pose d'angle
- Écran sur le couvercle pour les réglages de base et Wi-Fi intégré

- Schlicht und essentiell
- Für den Aufbau in einer Ecke geeignet
- Display an der Topplatte für die Regulierung der Hauptfunktionen und integriertes WiFi

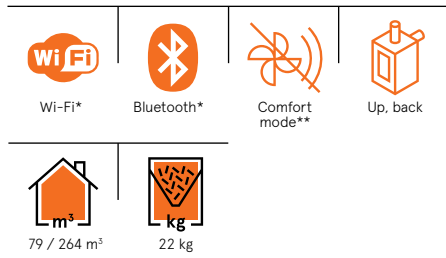

***Gestione tramite Wi-Fi e Bluetooth integrati**
Control through integrated Wi-Fi and Bluetooth
Gestion via Wi-Fi et Bluetooth intégré
Verwaltung über WiFi und integriertes Bluetooth

****Disattiva i ventilatori per garantire la massima silenziosità**
Deactivates stove fans, to guarantee maximum silence / Désactivés les ventilateurs afin de garantir le maximum de silence / Deaktivierung der Gebläse, um maximale Ruhe zu gewährleisten

11 kW

- Simple yet detailed design
- Large hopper
- High power for heating large spaces

- Design simple mais soigné dans les détails
- Réservoir de grande contenance
- Puissance importante pour chauffer de grands espaces

- Schlichtes, aber bis ins Detail gepflegtes Design
- Großer Behälter
- Große Leistung zum Heizen großer Räume



Prince 11

- Design semplice ma curato nei dettagli
- Ampio serbatoio
- Potenza importante per riscaldare grandi spazi

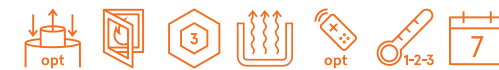

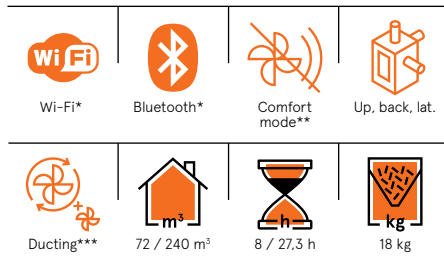

***Gestione tramite Wi-Fi e Bluetooth integrati**
Control through integrated Wi-Fi and Bluetooth
Gestion via Wi-Fi et Bluetooth intégré
Verwaltung über WiFi und integriertes Bluetooth

****Disattiva i ventilatori per garantire la massima silenziosità**
Deactivates stove fans, to guarantee maximum silence / Désactivés les ventilateurs afin de

garantir le maximum de silence / Deaktivierung der Gebläse, um maximale Ruhe zu gewährleisten

*****Canalizzazione 1 motore indipendente**
Duction with 1 independent motor
Conduits d'aération avec 1 moteur indépendant
Kanalisierung mit 1 unabhängigen Luftgebläse

10 kW

- Elegant shape
- Only 27 cm deep, for confined spaces
- Upper, back and lateral exhaust

- Forme élégante
- Seulement 27 cm de profondeur, pour les petits espaces
- Évacuation des fumées supérieure, arrière ou latérale

- Elegante Form
- Nur 27 cm Tiefe, für enge Platzverhältnisse
- Rauchgasabzug oben, hinten oder seitlich



Tile Plus 10



- Forma elegante
- Soli 27 cm di profondità, per gli spazi ristretti
- Scarico fumi superiore, posteriore o laterale

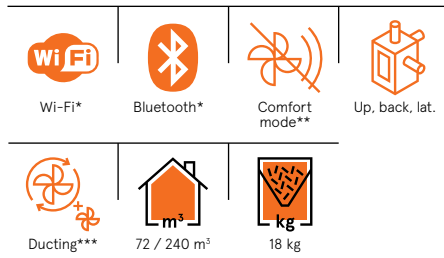

***Gestione tramite Wi-Fi e Bluetooth integrati**
Control through integrated Wi-Fi and Bluetooth
Gestion via Wi-Fi et Bluetooth intégré
Verwaltung über WiFi und integriertes Bluetooth

****Disattiva i ventilatori per garantire la massima silenziosità**
Deactivates stove fans, to guarantee maximum silence / Désactivés les ventilateurs afin de

garantir le maximum de silence / Deaktivierung der Gebläse, um maximale Ruhe zu gewährleisten

*****Canalizzazione 1 motore indipendente**
Duction with 1 independent motor
Conduits d'aération avec 1 moteur indépendant
Kanalisierung mit 1 unabhängigen Luftgebläse

10 kW



Wall Plus 10



- Design minimale
- Soli 29 cm di profondità, per gli spazi ristretti
- Perfetta per piccole pareti, corridoi o sospesa

- Minimalist design
- Only 29 cm deep, for confined spaces
- Perfect for small walls, corridors or to be suspended

- Design minimaliste
- Seulement 29 cm de profondeur, pour les petits espaces
- Parfait pour des murs de petite largeur, des couloirs ou l'installation suspendue

- Minimalistisches Design
- Nur 29 cm Tiefe, für enge Platzverhältnisse
- Perfekt für kleine Wände, Flure oder zum Aufhängen

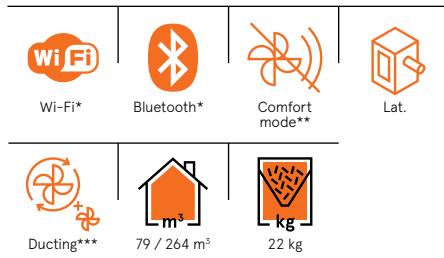

***Gestione tramite Wi-Fi e Bluetooth integrati**
Control through integrated Wi-Fi and Bluetooth
Gestion via Wi-Fi et Bluetooth intégré
Verwaltung über WiFi und integriertes Bluetooth

garantir le maximum de silence / Deaktivierung der Gebläse, um maximale Ruhe zu gewährleisten

****Disattiva i ventilatori per garantire la massima silenziosità**
Deactivates stove fans, to guarantee maximum silence / Désactivés les ventilateurs afin de

*****Canalizzazione 1 motore indipendente**
Duction with 1 independent motor
Conduits d'aération avec 1 moteur indépendant
Kanalisierung mit 1 unabhängigen Luftgebläse

11 kW

Sfera Plus 11



- Forma cilindrica essenziale
- Adatta per installazioni ad angolo
- Wifi integrato

- Basic cylindrical shape
- Suitable for corner installation
- Built-in Wi-Fi

- Forme cylindrique essentielle
- Indiqué pour une installation d'angle
- Wi-Fi intégré

- Essentielle zylindrische Form
- Zur Installation in einer Ecke geeignet
- Integriertes Wifi

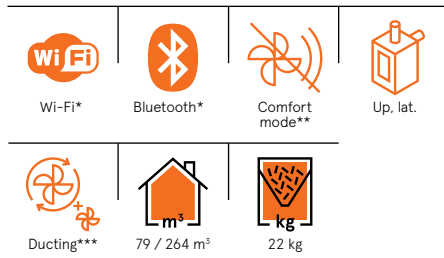

***Gestione tramite Wi-Fi e Bluetooth integrati**
Control through integrated Wi-Fi and Bluetooth
Gestion via Wi-Fi et Bluetooth intégré
Verwaltung über WiFi und integriertes Bluetooth

****Disattiva i ventilatori per garantire la massima silenziosità**
Deactivates stove fans, to guarantee maximum silence / Désactivés les ventilateurs afin de

garantir le maximum de silence / Deaktivierung der Gebläse, um maximale Ruhe zu gewährleisten

*****Canalizzazione 1 motore indipendente**
Duction with 1 independent motor
Conduits d'aération avec 1 moteur indépendant
Kanalisierung mit 1 unabhängigen Luftgebläse

11 kW



Prince Plus 11



- Design semplice e serbatoio capiente
- Potenza elevata con prezzo accessibile
- Uscita fumi e canalizzazione posteriore o superiore



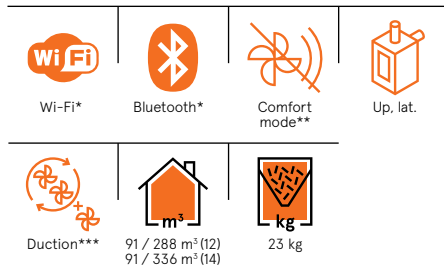

***Gestione tramite Wi-Fi e Bluetooth integrati**
Control through integrated Wi-Fi and Bluetooth
Gestion via Wi-Fi et Bluetooth intégré
Verwaltung über WiFi und integriertes Bluetooth

****Disattiva i ventilatori per garantire la massima silenziosità**
Deactivates stove fans, to guarantee maximum silence / Désactivés les ventilateurs afin de

garantir le maximum de silence / Deaktivierung der Gebläse, um maximale Ruhe zu gewährleisten

*****Canalizzazione 2 motori indipendenti**
Duction with 2 independ. motors Conduits d'aération avec 2 moteurs indépendants
Kanalisierung mit 2 unabhängigen Luftgebläsen

12/
14 kW



Atena Plus 12/14



- Dual rear or top ducting managed independently
- Built-in Wi-Fi for remote control
- Upper, back or exhaust
- Double canalisation arrière ou supérieure avec gestion indépendante
- Wi-Fi intégré pour le contrôle à distance
- Évacuation des fumées supérieure ou arrière
- Doppelte Luftkanalisierung mit unabhängiger Steuerung hinten oder oben
- Mit integriertem W-LAN zur Fernsteuerung
- Rauchgasabzug oben und hinten

- Doppia canalizzazione posteriore o superiore con gestione indipendente
- WiFi integrato per il controllo da remoto
- Scarico fumi superiore, posteriore o laterale

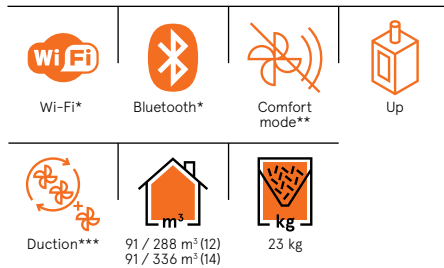

***Gestione tramite Wi-Fi e Bluetooth integrati**
Control through integrated Wi-Fi and Bluetooth
Gestion via Wi-Fi et Bluetooth intégré
Verwaltung über WiFi und integriertes Bluetooth

****Disattiva i ventilatori per garantire la massima silenziosità**
Deactivates stove fans, to guarantee maximum silence / Désactivés les ventilateurs afin de

garantir le maximum de silence / Deaktivierung der Gebläse, um maximale Ruhe zu gewährleisten

*****Canalizzazione 2 motori indipendenti**
Duction with 2 independ. motors Conduits d'aération avec 2 moteurs indépendants
Kanalisierung mit 2 unabhängigen Luftgebläsen

12/
14 kW



- Minimal design and multiple installation solutions
- Lower front ventilation grilles and improved air distribution
- Built-in Wi-Fi

- Design minimaliste et multiples solutions d'installation
- Grilles de ventilation frontales dans le bas et meilleure distribution de l'air
- Wi-Fi intégré

- Minimalistisches Design und viele Installationsmöglichkeiten
- Belüftungsgitter vorn unten und bessere Verteilung der Luft
- Integriertes Wifi



Mithos Plus 12/14

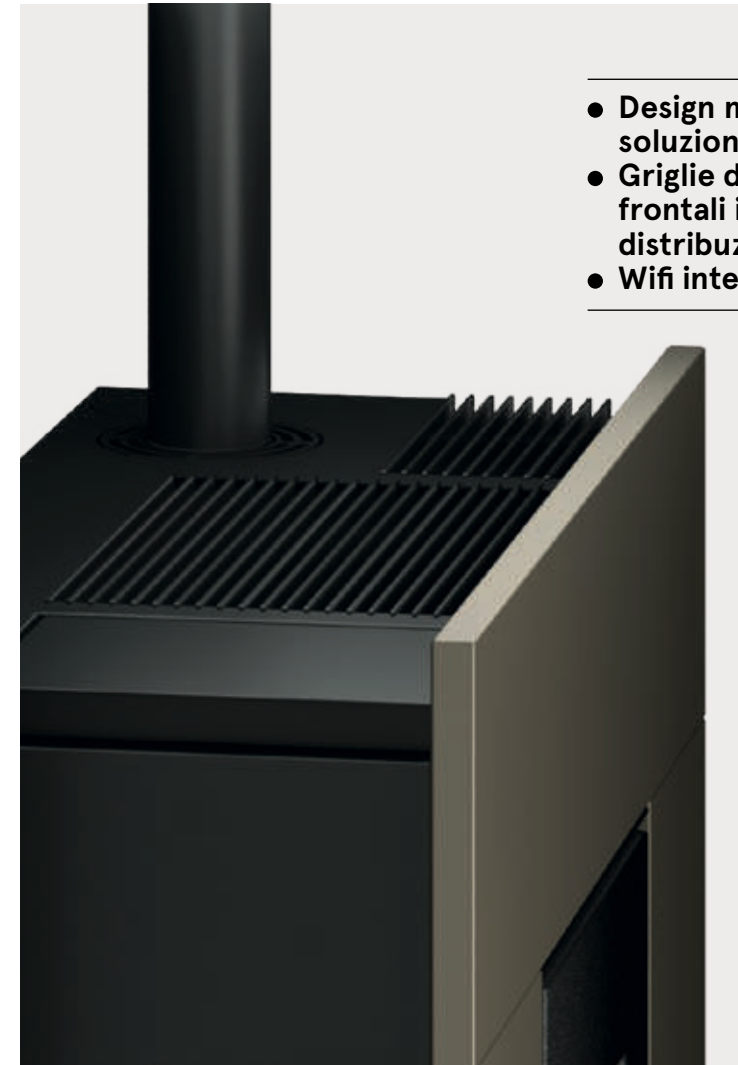

- Design minimal e molteplici soluzioni installative
- Griglie di ventilazione frontali inferiori e migliore distribuzione dell'aria
- Wifi integrato

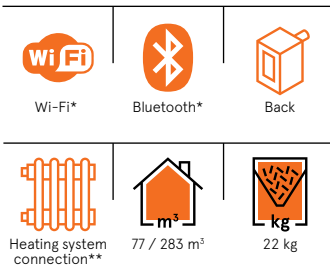

***Gestione tramite Wi-Fi e Bluetooth integrati**
Control through integrated Wi-Fi and Bluetooth
Gestion via Wi-Fi et Bluetooth intégré
Verwaltung über WiFi und integriertes Bluetooth

***Collegamento all'impianto di riscaldamento**
Connection to the heating system / Raccordement avec installation de chauffage / Anschluss zu Heizungssystem

11,8 kW

- Simple and neat design
- Optimised heat and optimal distribution
- Suitable for small homes

- Design simple et soigné
- Optimisation de la chaleur et distribution maximale
- Indiqué pour les petits logements

- Schlichtes und gepflegtes Design
- Optimierung der Wärme und maximale Verteilung
- Für kleine Wohnungen geeignet



Idro Prince 12

- Design semplice e curato
- Ottimizzazione del calore e massima distribuzione
- Adatta per piccole abitazioni



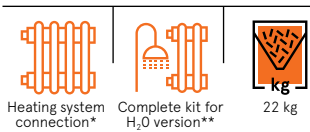

***Collegamento all'impianto di riscaldamento**
Connection to the heating system / Raccordement avec installation de chauffage / Anschluss zu Heizungssystem

****Kit completo Idro riscaldamento + acqua sanitaria** / Complete kit heating + domestic water
Kit complet Idro chauffage + eau sanitaire
Komplett-Set Hydro Heizung + Brauchwasser

15,2/
22,8 kW

Fino ad esaurimento
While stocks last
Jusqu'à épuisement
des stocks
Solange vorrat reicht

- Simple and neat design
- Powerful ventilation for optimal distribution
- Suitable for mid-sized homes

- Design simple et soigné
- Ventilation puissante pour une distribution maximale
- Indiqué pour les moyenne logements

- Schlichtes und gepflegtes Design
- Leistungsstarke Belüftung für maximalen Verteilung
- Für mittelgroßen Wohnungen geeignet



Idro Prince 16/23/23 H₂O



- Design semplice e curato
- Potente ventilazione per la massima distribuzione del calore
- Adatta per medie abitazioni





Wi-Fi*



Bluetooth*



Back

***Collegamento all'impianto di riscaldamento**
Connection to the heating system / Raccordement avec installation de chauffage / Anschluss zu Heizungssystem

****Kit completo Idro riscaldamento + acqua sanitaria** / Complete kit heating + domestic water
Kit complet Idro chauffage + eau sanitaire
Komplett-Set Hydro Heizung + Brauchwasser

15,2/
22,8 kW



Heating system connection*



Complete kit for H₂O version**



113 / 389 m² (16)
113 / 547 m² (23)



22 Kg



Idro River

16/23/23 H₂O







- Linee morbide dal sapore classico contemporaneo
- Nuova stufa idro ventilata
- Rivestimenti in metallo o in pregiata ceramica



- Soft lines with a classic contemporary feel
- New ventilated hydro stove
- Metal cladding or high-quality ceramics

- Des lignes souples avec une touche classique contemporaine
- Nouveau poêle hydro ventilé
- Revêtements en métal ou céramique précieuse

- Weiche Linien mit klassischem, modernem Look
- Neuer belüfteter wasserführender Ofen
- Verkleidungen aus Metall oder aus edler Keramik

 Wi-Fi*	 Bluetooth*	 Up
 Collegam. imp. riscaldamento*	 139/432 m ² (16) 139/593 m ² (24)	 10,3/33,3 h (16) 7,3/33,3 h (24)
	 40 kg	

***Gestione tramite Wi-Fi e Bluetooth integrati**
Control through integrated Wi-Fi and Bluetooth
Gestion via Wi-Fi et Bluetooth intégrés
Verwaltung über WiFi und integriertes Bluetooth

****Kit completo Idro riscaldamento + acqua sanitaria** / Complete kit heating + domestic water
Kit complet Idro chauffage + eau sanitaire
Komplett-Set Hydro Heizung + Brauchwasser

18/
24,7 kW

- Insert with a minimalist design, with a large view of the fire
- Available with outputs of 16 and 24 kW with front ventilation
- Built-in Wi-Fi and Bluetooth

- Un insert au design minimaliste, avec une grande vue du feu
- Disponible dans une puissance de 16 et 24 kW avec ventilation frontale
- Wi-Fi et Bluetooth intégrés







- Kamineinsatz mit minimalistischem Design mit guter Sicht auf das Feuer
- Mit 16 und 24 kW Leistung und Frontgebläse erhältlich
- Wifi und Bluetooth integriert



Saturno 16/24

- **Inserto dal design minimale, con ampia visione del fuoco**
- **Disponibile nelle potenze di 16 e 24 kW con ventilazione frontale**
- **Wifi e Bluetooth integrato**



					
---	---	---	---	---	---



Wi-Fi*



Bluetooth*



Up, back

***Gestione tramite Wi-Fi e Bluetooth integrati**
 Control through integrated Wi-Fi and Bluetooth
 Gestion via Wi-Fi et Bluetooth intégré
 Verwaltung über WiFi und integriertes Bluetooth

***Collegamento all'impianto di riscaldamento**
 Connection to the heating system / Raccordement avec installation de chauffage / Anschluss zu Heizungssystem

16,2/
22,8 kW



Heating system connection**



113 / 389 m² (16)
113 / 547 m² (24)



22 kg

Maya 16/24

- Nuovo modello disponibile nelle potenze di 16 e 24 kW
- Ventilata e pensata per gli spazi ristretti
- Rivestimento in metallo in vari colori

- New model available with outputs of 16 and 24 kW
- Ventilated and designed for confined spaces
- Metal cladding in various colours
- Nouveau modèle disponible dans les puissances 16 et 24 kW
- Ventilé et conçu pour les petits espaces
- Revêtement en métal de différentes couleurs
- Neues Modell, das mit 16 und 24 kW Leistung erhältlich ist
- Belüftet und für enge Platzverhältnisse gedacht
- Metallverkleidung in mehreren Farben



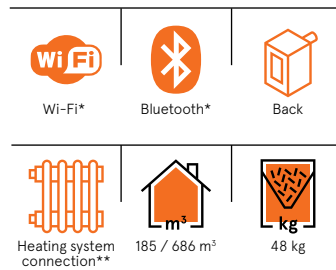

***Gestione tramite Wi-Fi e Bluetooth integrati**
Control through integrated Wi-Fi and Bluetooth
Gestion via Wi-Fi et Bluetooth intégré
Verwaltung über WiFi und integriertes Bluetooth

***Collegamento all'impianto di riscaldamento**
Connection to the heating system / Raccordement avec installation de chauffage / Anschluss zu Heizungssystem

28,6 kW

- La più potente tra le Hydro
- Serbatoio 48 kg
- WiFi esterno incluso



Idro Prince 30



- The most powerful of the Hydro stoves
- 48 kg hopper
- External Wi-Fi included
- Le plus puissant parmi les Hydro
- Réservoir de 48 kg
- Wi-Fi externe inclus
- Der leistungstärkste unter den wasserführenden Öfen
- 48 kg Behälter
- Externes WiFi inbegriffen

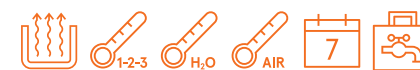



6,2/
7,5 kW

Smart 60/80

- **Porte in ghisa, eleganti maniglie e corrimano in acciaio**
- **Da incasso e a libera installazione**
- **Con piedini estetici o zoccolo in acciaio**



- Cast iron doors, elegant handles and steel handrail
- Recessed or free installation
- With aesthetic feet or steel basement
- Portes en fonte, poignées élégantes et mains courantes en acier
- Encastrable ou en pose libre
- Avec pieds décoratifs ou socle en acier
- Türen aus Gusseisen, elegante Griffe und Handlauf aus Stahl
- Zum Einbau oder freistehend
- Mit Zierfüßen oder Stahlsockel





Built-in



Up, back

6,2/
7,5 kW



- **Da incasso**
- **Camera di combustione con interno in refrattario**
- **Ampio vetro per vista sul forno**

Kook

- Recessed
- Combustion chamber with refractory stone interior
- Large glass window offering a view on the oven
- Encastrable
- Chambre de combustion avec intérieur en matériau réfractaire
- Grande vitre pour une meilleure vue du four
- Zum Einbau
- Brennkammer mit feuerbeständigem Innenraum
- Große Glasscheibe für den Blick aufs Feuer



Technical features

Pellet Air

- P. 70 **Spirit 5**
- P. 71 **Sound 5 Up**
- P. 71 **Sound 7 Up**
- P. 72 **Grace 7**
- P. 72 **Cristal 7**
- P. 73 **Cristal 7 Up**
- P. 73 **Sweet 7**
- P. 74 **Perla 7**
- P. 74 **Kriss 9**
- P. 75 **Cristal 9**
- P. 75 **Quasimodo 9 Up**
- P. 76 **Zefiro 9**
- P. 76 **Frame 9**
- P. 77 **Frame 9 Up**
- P. 77 **Shell Up 11**
- P. 78 **Shell Ps 11**
- P. 78 **Sfera 11**
- P. 79 **Prince 11**

Pellet Air Plus

- P. 80 **Tile Plus 10**
- P. 81 **Wall Plus 10**
- P. 81 **Sfera Plus 11**
- P. 82 **Prince Plus 11**
- P. 82 **Atena Plus 12**
- P. 83 **Atena Plus 14**
- P. 83 **Mithos Plus 12**
- P. 84 **Mithos Plus 14**

Pellet Hydro

- P. 85 **Idro Prince 12**
- P. 86 **Idro Prince 16**
- P. 86 **Idro Prince 23/23 H₂O**
- P. 87 **Idro River 16**
- P. 87 **Idro River 23/23 H₂O**
- P. 88 **Saturno 16**
- P. 88 **Saturno 24**
- P. 89 **Maya 16**
- P. 89 **Maya 24**
- P. 90 **Idro Prince 30**

Wood

- P. 91 **Smart 60**
- P. 92 **Smart 80**
- P. 92 **Kook 60 4.0**
- P. 93 **Kook 70 4.0**
- P. 93 **Kook 80 4.0**
- P. 94 **Kook 90 4.0**
- P. 94 **Kook 67**
- P. 95 **Kook 87**

Pellet Air

Stufe ad aria ventilata dotate di camera stagna, con potenze da 5 a 11 kW

Stove with ventilated air and sealed chamber, with outputs from 5 to 11 kW

Poêles à air ventilé avec chambre étanche, puissance de 5 à 11 kW

Luftführende belüftete Öfen mit abgedichteter Kammer und Leistung zwischen 5 und 11 kW

Spirit 5 ● 5,2 kW P. 12



A+

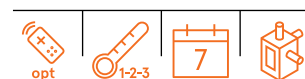
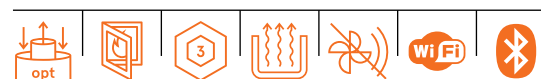
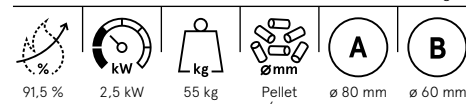
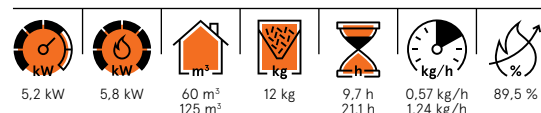
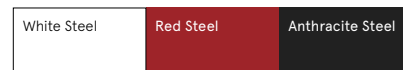
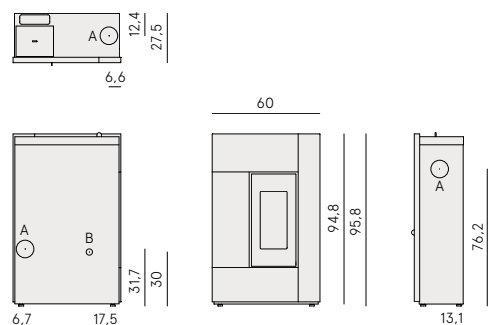

European standards Art. 15A B-VG 2015 BImSchV 2015 Regensburg
 München Stuttgart Aachen EN 14785:2006
 CE Certificate model name: SPIRIT3 5kW



Sound 5 Up ● 5,5 kW P. 14



A+

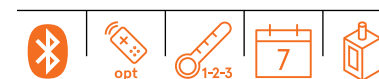
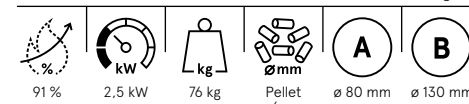
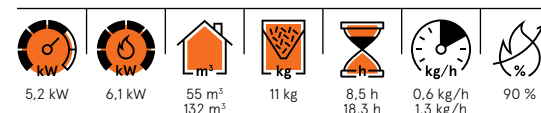
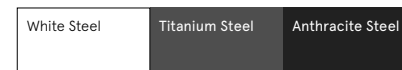
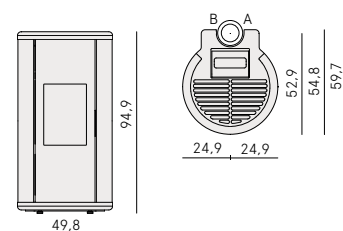

European standards Art. 15A B-VG 2015 BImSchV 2015 Regensburg
 München Stuttgart Aachen EN 14785:2006
 CE Certificate model name: SOUND3 5 UP



**** Prodotto in possesso dei requisiti per il raggiungimento delle 4 stelle aria pulita

Sound 7 Up ● 7 kW P. 14



A+

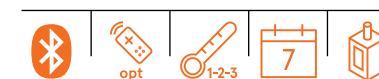
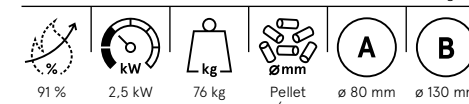
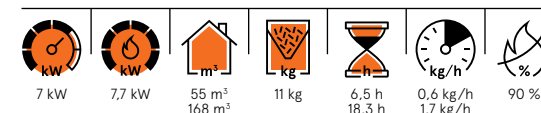
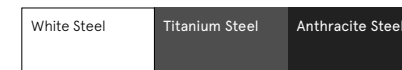
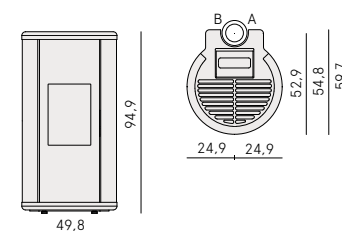

European standards Art. 15A B-VG 2015 BImSchV 2015 Regensburg
 München Stuttgart Aachen EN 14785:2006
 CE Certificate model name: SOUND3 7 UP



**** Prodotto in possesso dei requisiti per il raggiungimento delle 4 stelle aria pulita

Grace 7 ● 7 kW

P. 16



A+

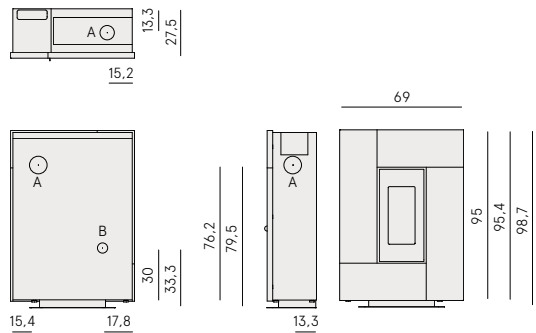

White Steel	Red Steel	Anthracite Steel
Black Glass	Light Bronze Steel	Serpentino Stone

7 kW	7.8 kW	60 m³ 168 m³	12 kg	7.1 h 19.7 h	0.61 kg/h 1.70 kg/h	89.5 %
------	--------	-----------------	-------	-----------------	------------------------	--------

93 %	2.7 kW	63.5 kg 72 kg 80 kg	Pellet ø 6 mm	A	B
------	--------	---------------------------	------------------	---	---

--	--	--	--	--

--	--	--	--

European standards Art. 15A B-VG 2015 BImSchV 2015 Regensburg
München Stuttgart Aachen EN 14785:2006
CE Certificate model name: GRACE3



Cristal 7 ● 7 kW

P. 18



A+

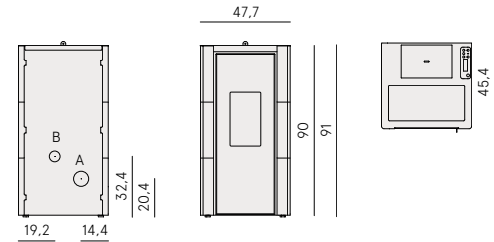

White Steel	Red Steel	Anthracite Steel
-------------	-----------	------------------

7 kW	7.7 kW	55 m³ 168 m³	15 kg	8.8 h 25 h	0.6 kg/h 1.7 kg/h	90 %
------	--------	-----------------	-------	---------------	----------------------	------

91 %	2.5 kW	56 kg	Pellet ø 6 mm	A	B
------	--------	-------	------------------	---	---

--	--	--	--	--

--	--	--	--

European standards Art. 15A B-VG 2015 BImSchV 2015 Regensburg
München Stuttgart Aachen EN 14785:2006
CE Certificate model name: CRISTAL3 7.0



Cristal 7 Up ● 7 kW

P. 18



A+

New

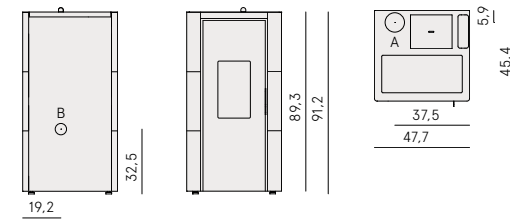

White Steel	Red Steel	Anthracite Steel
-------------	-----------	------------------

7 kW	7.7 kW	55 m³ 168 m³	12 kg	7.1 h 20 h	0.6 kg/h 1.7 kg/h	90 %
------	--------	-----------------	-------	---------------	----------------------	------

91 %	2.5 kW	56 kg	Pellet ø 6 mm	A	B
------	--------	-------	------------------	---	---

--	--	--	--	--	--

--	--	--

European standards Art. 15A B-VG 2015 BImSchV 2015 Regensburg
München Stuttgart Aachen EN 14785:2006
CE Certificate model name: CRISTAL3 7.0 UP



Sweet 7 ● 7 kW

P. 20



A+

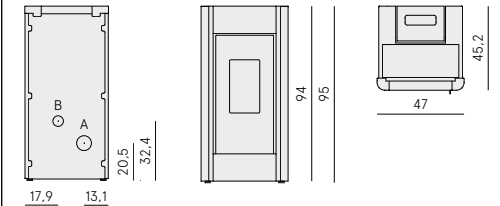

White Steel	Red Steel	Anthracite Steel
-------------	-----------	------------------

7 kW	7.7 kW	55 m³ 168 m³	15 kg	8.8 h 25 h	0.6 kg/h 1.7 kg/h	90 %
------	--------	-----------------	-------	---------------	----------------------	------

91 %	2.5 kW	56 kg	Pellet ø 6 mm	A	B
------	--------	-------	------------------	---	---

--	--	--	--	--

--	--	--	--

European standards Art. 15A B-VG 2015 BImSchV 2015 Regensburg
München Stuttgart Aachen EN 14785:2006
CE Certificate model name: SWEET3 7.0



Perla 7 ● 7 kW

P. 22



A+

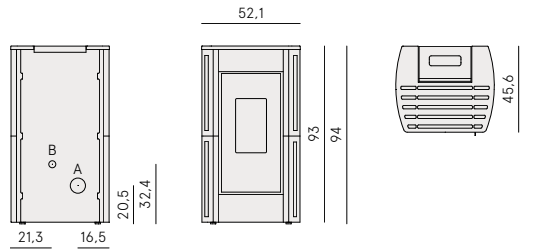

White Majolica	Ivory Majolica	Red Majolica
White Steel	Red Steel	Anthraccite Steel

7 kW	7.7 kW	55 m³ 168 m³	15 kg	8.8 h 25 h	0.6 kg/h 1.7 kg/h	90 %
------	--------	-----------------	-------	---------------	----------------------	------

91 %	2.5 kW	60 kg 67 kg	Pellet ø 6 mm	A	B
------	--------	----------------	------------------	---	---

--	--	--	--	--

--	--	--	--

European standards Art. 15A B-VG 2015 BImSchV 2015 Regensburg München Stuttgart Aachen EN 14785:2006 **CE** Certificate model name: PERLA3 7.0

				**** Prodotto in possesso dei requisiti per il raggiungimento delle 4 stelle aria pulita

Kriss 9 ● 8,6 kW

P. 24



A+

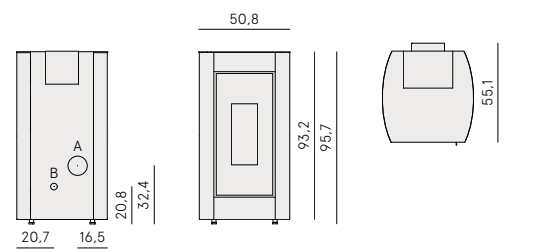

White Steel	Light Bronze Steel	Red Steel	Anthraccite Steel
-------------	--------------------	-----------	-------------------

8,6 kW	9,7 kW	58 m³ 206 m³	18 kg	9 h 34 h	0,53 kg/h 2,01 kg/h	89,1 %
--------	--------	-----------------	-------	-------------	------------------------	--------

92,9 %	2,4 kW	88 kg	Pellet ø 6 mm	A	B
--------	--------	-------	------------------	---	---

--	--	--	--	--

--	--	--	--

European standards Art. 15A B-VG 2015 BImSchV 2015 Regensburg München Stuttgart Aachen EN 14785:2006 **CE** Certificate model name: KRISS3-8,5kW

				**** Prodotto in possesso dei requisiti per il raggiungimento delle 4 stelle aria pulita

Cristal 9 ● 8,6 kW

P. 26



A+

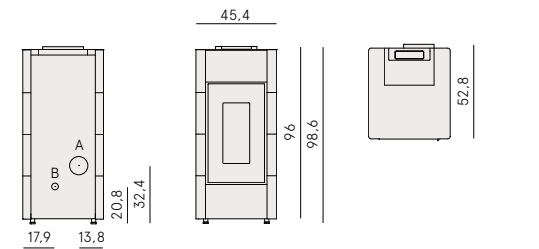

White Steel	Red Steel	Anthraccite Steel
-------------	-----------	-------------------

8,6 kW	9,7 kW	58 m³ 206 m³	18 kg	9 h 34 h	0,54 kg/h 2,01 kg/h	89,1 %
--------	--------	-----------------	-------	-------------	------------------------	--------

92,9 %	2,4 kW	79 kg	Pellet ø 6 mm	A	B
--------	--------	-------	------------------	---	---

--	--	--	--	--

--	--	--	--

European standards Art. 15A B-VG 2015 BImSchV 2015 Regensburg München Stuttgart Aachen EN 14785:2006 **CE** Certificate model name: CRISTAL3-8,5kW

				**** Prodotto in possesso dei requisiti per il raggiungimento delle 4 stelle aria pulita

Quasimodo 9 Up ● 9,3 kW

P. 28



A+

New

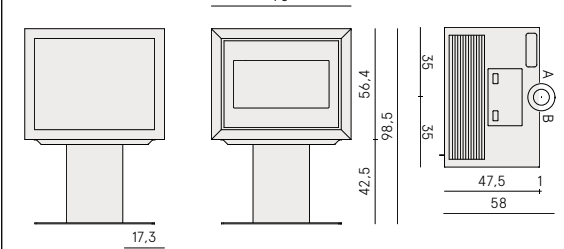

Black Steel

9,3 kW	10,5 kW	65 m³ 223 m³	11,5 kg	5,3 h 19 h	0,59 kg/h 2,18 kg/h	89 %
--------	---------	-----------------	---------	---------------	------------------------	------

93,9 %	2,7 kW	95 kg	Pellet ø 6 mm	A	B
--------	--------	-------	------------------	---	---

--	--	--	--	--

--	--	--	--

European standards Art. 15A B-VG 2015 BImSchV 2015 Regensburg München Stuttgart Aachen EN 14785:2006 **CE** Certificate model name: QUASIMODO3 UP

				**** Prodotto in possesso dei requisiti per il raggiungimento delle 4 stelle aria pulita

Zefiro 9 ● 9,3 kW
P. 30



A+

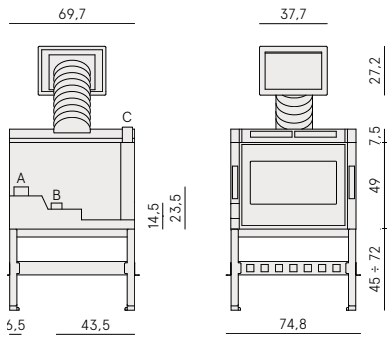

Black Glass

9,3 kW	10,5 kW	65 m² 223 m³	15 kg	6,9 h 25 h	0,59 kg/h 2,17 kg/h	88,4 %
94,2 %	2,7 kW	94 kg	Pellet ø 6 mm	A	B	C
opt	3					
opt	1-2-3	7		opt		

European standards Art. 15A B-VG 2015 BImSchV 2015 Regensburg München Stuttgart Aachen EN 14785:2006 **CE** Certificate model name: ZEFIRO3 9kW



Frame 9 ● 9,3 kW
P. 32



A+

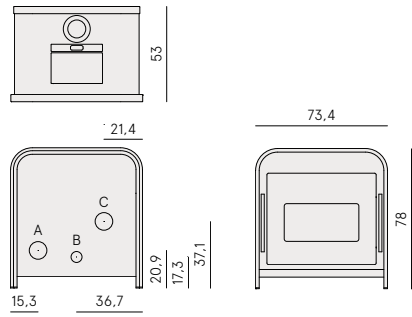

Light Bronze Steel Anthracite Steel Black Steel

9,3 kW	10,5 kW	65 m² 223 m³	15 kg	6,9 h 25 h	0,59 kg/h 2,18 kg/h	89 %
93,9 %	2,7 kW	105 kg	Pellet ø 6 mm	A	B	C
3					opt	
1-2-3	7		opt			

European standards Art. 15A B-VG 2015 BImSchV 2015 Regensburg München Stuttgart Aachen EN 14785:2006 **CE** Certificate model name: FRAME3 9 kW



Frame 9 Up ● 9,3 kW
P. 32



A+

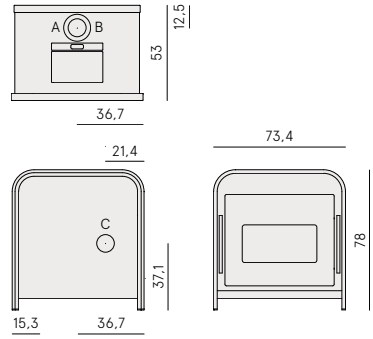

Light Bronze Steel Anthracite Steel Black Steel

9,3 kW	10,5 kW	65 m² 223 m³	15 kg	6,9 h 25 h	0,59 kg/h 2,18 kg/h	89 %
93,9 %	2,7 kW	105 kg	Pellet ø 6 mm	A	B	C
opt	3					
opt	1-2-3	7		opt		

European standards Art. 15A B-VG 2015 BImSchV 2015 Regensburg München Stuttgart Aachen EN 14785:2006 **CE** Certificate model name: FRAME3 UP 9 kW



Shell 9 Up ● 9,1 kW
P. 34



A+

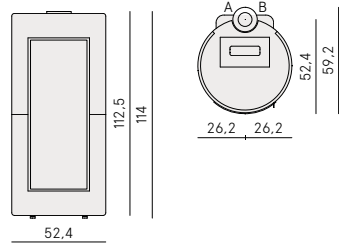

White Steel Titanium Steel Dark Bronze Steel Anthracite Steel

9,1 kW	10,3 kW	58 m² 218 m³	17 kg	8 h 32,1 h	0,53 kg/h 2,12 kg/h	88,7 %
92,9 %	2,4 kW	88 kg	Pellet ø 6 mm	A	B	
opt	3					
opt	1-2-3	7				

European standards Art. 15A B-VG 2015 BImSchV 2015 Regensburg München Stuttgart Aachen EN 14785:2006 **CE** Certificate model name: SHELL 3 UP



Shell 9 Ps ● 9,1 kW

P. 34



A+

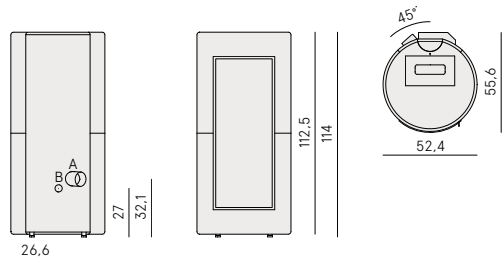

White Steel	Titanium Steel	Dark Bronze Steel	Anthracite Steel
-------------	----------------	-------------------	------------------

9,1 kW	10,3 kW	58 m³ 218 m³	17 kg	8 h 32,1 h	0,53 kg/h 2,12 kg/h	88,7 %
--------	---------	-----------------	-------	---------------	------------------------	--------

92,9 %	2,4 kW	85,3 kg	Pellet ø 6 mm	A	B
--------	--------	---------	------------------	---	---

--	--	--	--

--	--	--

European standards Art. 15A B-VG 2015 BImSchV 2015 Regensburg München Stuttgart Aachen EN 14785:2006 **CE** Certificate model name: SHELL 3 PS

Sfera 11 ● 11 kW

P. 36



A+

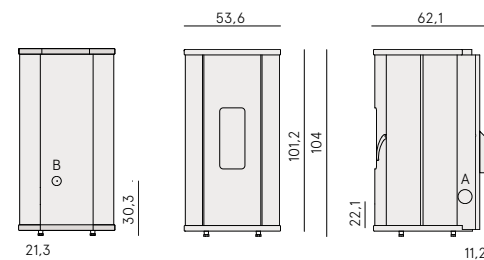

White Steel	Titanium Steel	Red Steel
Dark Bronze Steel	Anthracite Steel	

11 kW	12,1 kW	79 m³ 264 m³	22 kg	8,5 h 30 h	0,73 kg/h 2,6 kg/h	91 %
-------	---------	-----------------	-------	---------------	-----------------------	------

93,5 %	3,3 kW	104,2 kg	Pellet ø 6 mm	A	B
--------	--------	----------	------------------	---	---

--	--	--	--	--

--	--	--

European standards Art. 15A B-VG 2015 BImSchV 2015 Regensburg München Stuttgart Aachen EN 14785:2006 **CE** Certificate model name: SFERA3 11kW

Prince 11 ● 11 kW

P. 38



A+

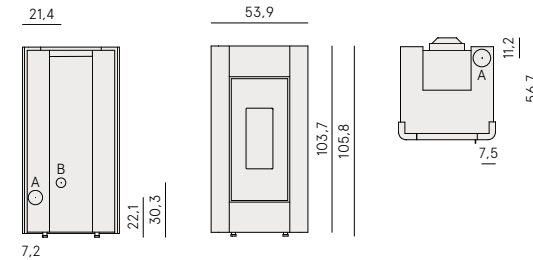

White Steel	Light Bronze Steel	Titanium Steel
Red Steel	Anthracite Steel	

11 kW	12,1 kW	79 m³ 264 m³	22 kg	8,5 h 30 h	0,73 kg/h 2,6 kg/h	91 %
-------	---------	-----------------	-------	---------------	-----------------------	------

93,5 %	3,3 kW	108,7 kg	Pellet ø 6 mm	A	B
--------	--------	----------	------------------	---	---

--	--	--	--

--	--	--	--	--

European standards Art. 15A B-VG 2015 BImSchV 2015 Regensburg München Stuttgart Aachen EN 14785:2006 **CE** Certificate model name: PRINCE3 11kW

Pellet Air Plus

Tile Plus 10 ● 10 kW
P. 40



A+

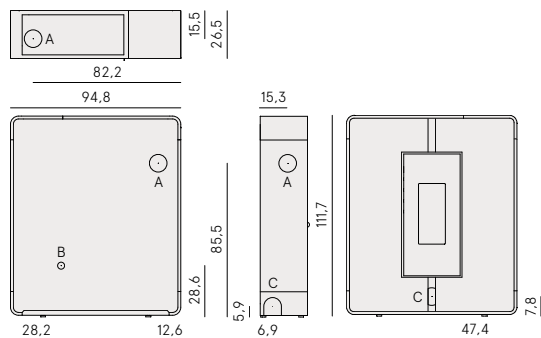

White Steel Light Bronze Steel Titanium Steel
Red Steel Anthracite Steel

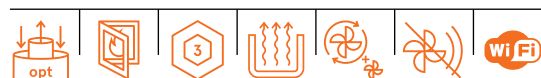
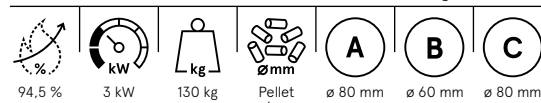

European standards Art. 15A B-VG 2015 BImSchV 2015 Regensburg München Stuttgart Aachen EN 14785:2006 **CE** Certificate model name: TILE3 PLUS



Wall Plus 10 ● 10 kW
P. 42



A+

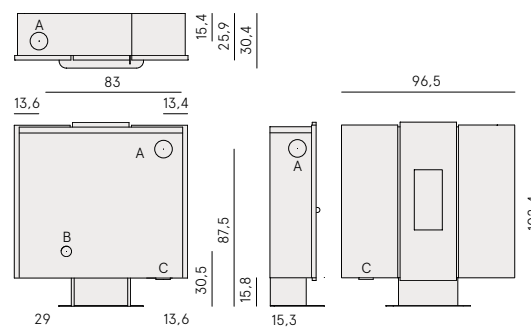

White Steel Red Steel

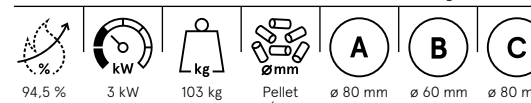

European standards Art. 15A B-VG 2015 BImSchV 2015 Regensburg München Stuttgart Aachen EN 14785:2006 **CE** Certificate model name: WALL3 PLUS



Sfera Plus 11 ● 11 kW
P. 44



A+

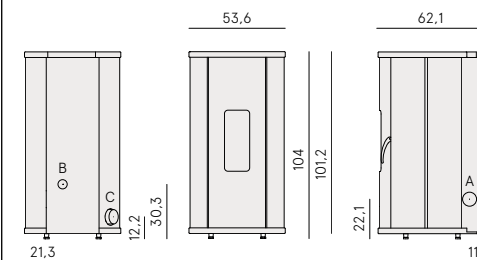

White Steel Titanium Steel Red Steel
Dark Bronze Steel Anthracite Steel

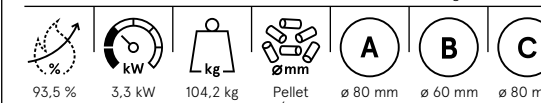

European standards Art. 15A B-VG 2015 BImSchV 2015 Regensburg München Stuttgart Aachen EN 14785:2006 **CE** Certificate model name: SFERA3 PLUS 11kW



Mithos Plus 14 ● 14 kW

P. 50



A+

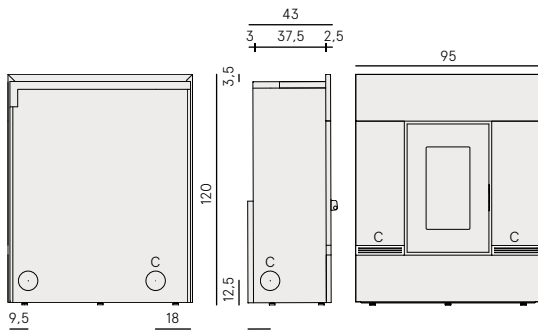

- White Steel
- Light Bronze Steel
- Titanium Steel
- Red Steel
- Anthracite Steel

14 kW	15.7 kW	91 m³ 336 m³	23 kg	7 h 27 h	0,86 kg/h 3,5 kg/h	89 %
-------	---------	-----------------	-------	-------------	-----------------------	------

93,5 %	3,8 kW	165 kg	Pellet ø 6 mm	A	B	C
				ø 80 mm	ø 130 mm	ø 80 mm

--	--	--	--	--	--	--

--	--	--	--	--	--

European standards Art. 15A B-VG 2015 BImSchV 2015 Regensburg
München Stuttgart Aachen EN 14785:2006
CE Certificate model name: MITHOS3 PLUS 14

			Conto termico	**** Prodotto in possesso dei requisiti per il raggiungimento delle 4 stelle aria pulita

Pellet Hydro

La soluzione ideale per chi vuole scaldare anche i termosifoni e raggiungere un calore confortevole ed uniforme in tutta la casa

The ideal solution for customers who also want to heat radiators and enjoy a cosy temperature with evenly distributed heat throughout the house

La solution idéale pour chauffer aussi les radiateurs et obtenir une chaleur confortable et uniforme dans toute la maison

Die ideale Lösung, wenn auch die Heizkörper beheizt werden sollen und im gesamten Haus eine komfortable, gleichmäßige Wärme gewünscht ist

Idro Prince 12 ● 11,8 kW

P. 52



A+

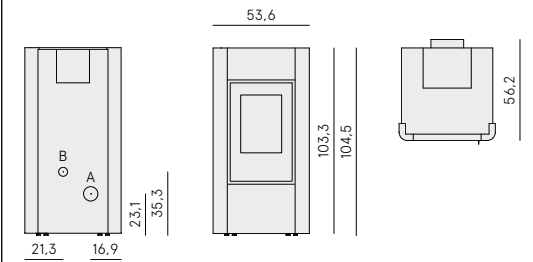

- White Steel
- Light Bronze Steel
- Titanium Steel
- Red Steel
- Anthracite Steel

11.8 kW	12.9 kW	77 m³ 283 m³	22 kg	8,5 h 31,4 h	10,2 kW	2,2 kW
---------	---------	-----------------	-------	-----------------	---------	--------

0,7 kg/h 2,6 kg/h	3,2 kW	91,8 %	92,4 %	132,1 kg	Pellet ø 6 mm	A
						ø 80 mm

B				
ø 50 mm				

--	--	--	--	--	--

European standards Art. 15A B-VG 2015 BImSchV 2015 Regensburg
München Stuttgart Aachen EN 14785:2006
CE Certificate model name: IDRO PRINCE3 12

			Conto termico	

Idro Prince 16 ● 16,2 kW

P. 54

Fino ad esaurimento
While stocks last
Jusqu'à épuisement
des stocks
Solange vorrat reicht



A+

Idro Prince 23/23 H₂O

● 22,8 kW

P. 54

Fino ad esaurimento
While stocks last
Jusqu'à épuisement
des stocks
Solange vorrat reicht



A+

Idro River 16 ● 16,2 kW

P. 56

New



A+

Idro River 23/23 H₂O

● 22,8 kW

P. 56

New



A+

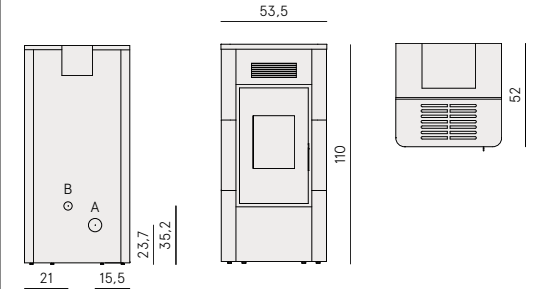
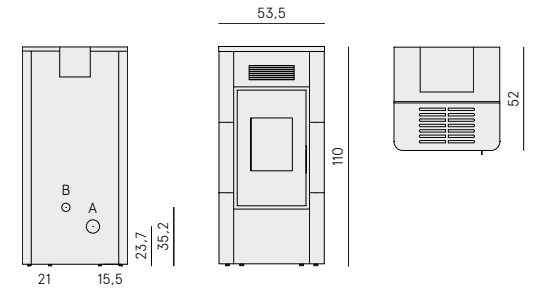
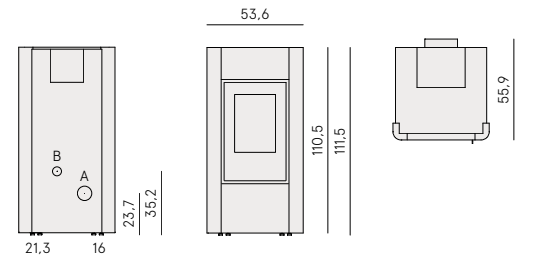
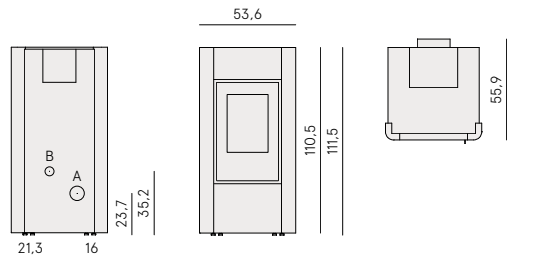

White Steel	Light Bronze Steel	Titanium Steel
Red Steel	Anthracite Steel	

White Steel	Light Bronze Steel	Titanium Steel
Red Steel	Anthracite Steel	

White Majolica	Ivory Majolica	Red Majolica	White Steel
Light Bronze Steel	Red Steel	Titanium Steel	Anthracite Steel

White Majolica	Ivory Majolica	Red Majolica	White Steel
Light Bronze Steel	Red Steel	Titanium Steel	Anthracite Steel

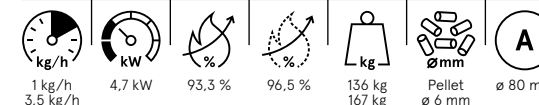
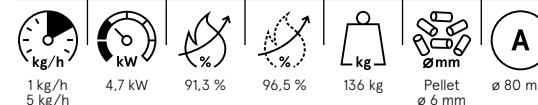
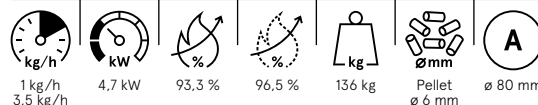

European standards Art. 15A B-VG 2015 BImSchV 2015 Regensburg
München Stuttgart Aachen EN 14785:2006
CE Certificate model name: IDRO PRINCE3 16

European standards Art. 15A B-VG 2015 BImSchV 2015 Regensburg
München Stuttgart Aachen EN 14785:2006
CE Certificate model name: IDRO PRINCE3 23

European standards BImSchV 2015 Regensburg München
Stuttgart Aachen EN 14785:2006
CE Certificate model name: IDRO RIVER3 16

European standards BImSchV 2015 Regensburg München
Stuttgart Aachen EN 14785:2006
CE Certificate model name: IDRO RIVER3 23



**** Prodotto in possesso dei requisiti per il raggiungimento delle 4 stelle aria pulita

**** Prodotto in possesso dei requisiti per il raggiungimento delle 4 stelle aria pulita

Saturno 16 ● 18 kW

P. 58



A++

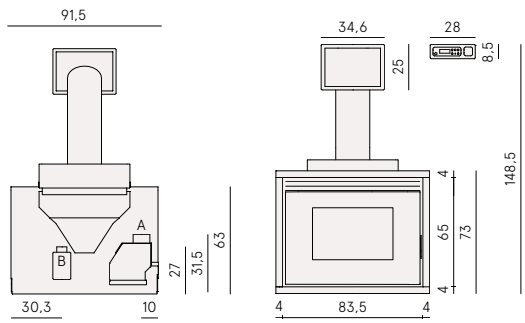

Black Steel

18 kW	19.1 kW	139 m³ 432 m³	40 kg	10.3 h 33.3 h	13 kW	3.8 kW
1.2 kg/h 3.9 kg/h	5.8 kW	94.2 %	95.9 %	230 kg	Pellet ø 6 mm	A
B					ø 50 mm	



European standards BImSchV 2015 Regensburg München
Stuttgart Aachen EN 14785:2006
CE Certificate model name: SATURNO 16



Saturno 24 ● 24,7 kW

P. 58



A++

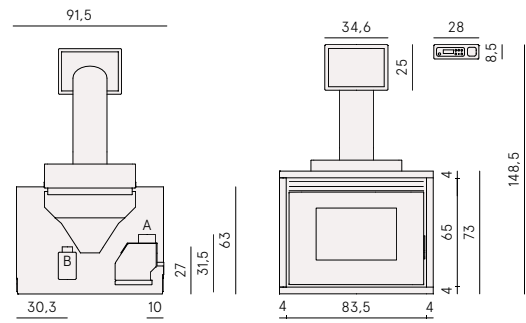

Black Steel

24.7 kW	26.5 kW	139 m³ 593 m³	40 kg	7.3 h 33.3 h	19 kW	3.8 kW
1.2 kg/h 5.5 kg/h	5.8 kW	93.3 %	95.9 %	230 kg	Pellet ø 6 mm	A
B					ø 50 mm	



European standards Art. 15A B-VG 2015 BImSchV 2015 Regensburg
München Stuttgart Aachen EN 14785:2006
CE Certificate model name: SATURNO 24



Maya 16 ● 16,2 kW

P. 60



A+

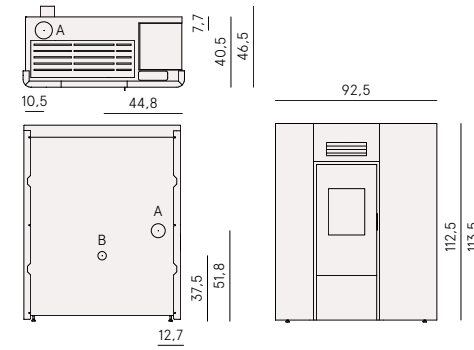

White Steel | Light Bronze Steel | Titanium Steel
Red Steel | Anthracite Steel

16.2 kW	17.4 kW	113 m³ 389 m³	22 kg	6.3 h 22 h	12.9 kW	3.1 kW
1 kg/h 3.5 kg/h	4.7 kW	93.3 %	96.5 %	167 kg	Pellet ø 6 mm	A
B						



European standards BImSchV 2015 Regensburg München
Stuttgart Aachen EN 14785:2006
CE Certificate model name: MAYA3 16



Maya 24 ● 22,8 kW

P. 60



A+

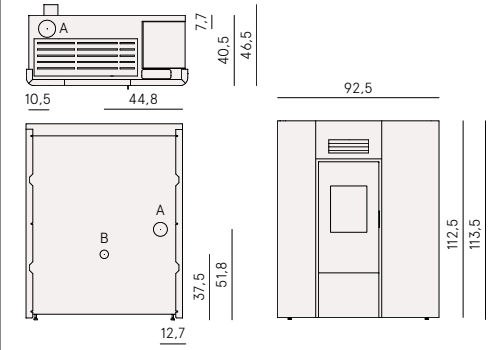

White Steel | Light Bronze Steel | Titanium Steel
Red Steel | Anthracite Steel

22.8 kW	25 kW	113 m³ 547 m³	22 kg	4.4 h 22 h	18.7 kW	3.1 kW
1 kg/h 5 kg/h	4.7 kW	91.3 %	96.5 %	167 kg	Pellet ø 6 mm	A
B						



European standards BImSchV 2015 Regensburg München
Stuttgart Aachen EN 14785:2006
CE Certificate model name: MAYA3 24



Idro Prince 30 ● 28,6 kW

P. 62



A+

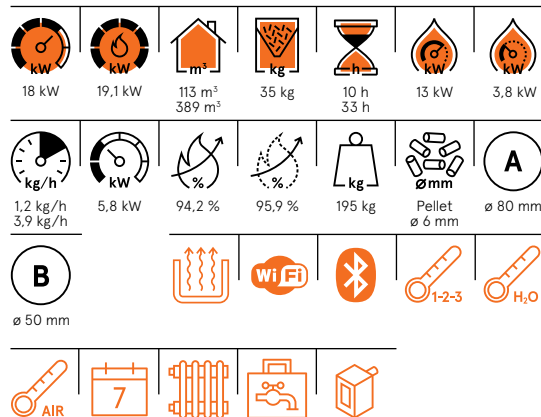
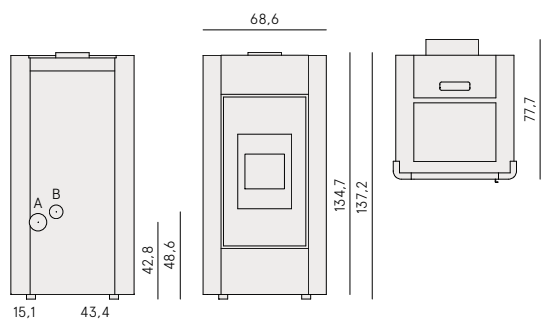

European standards Art. 15A B-VG 2015 BImSchV 2015 Regensburg
 München Stuttgart Aachen EN 14785:2006
 CE Certificate model name: IDRO PRINCE 30



Wood

Cucine economiche a legna a libera installazione e da incasso caratterizzate per unire il calore alla cottura

Free-standing and recessed wood-burning stoves that combine heat and cooking in one

Des cuisinières à bois à prix réduits, encastrables ou en pose libre pour cuisiner et chauffer en même temps

Holzherde, freistehend oder zum Einbau:
 Heizen und Kochen in einem

Smart 60 ● 6,5 kW

P. 64



A+

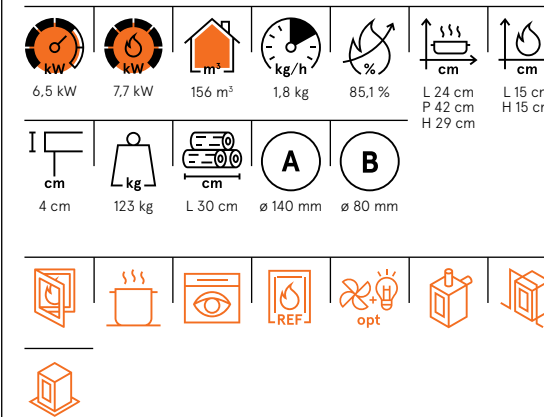
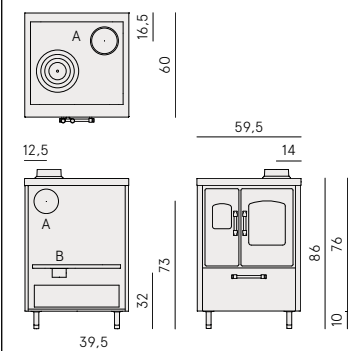

European standards Art. 15A B-VG 2015 BImSchV 2015 Regensburg München
 Stuttgart Aachen EN 12815:2001/A1:2004/AC:2007
 CE Certificate model name: SMART 60, SMART 60V, SMART 60S, SMART 60VS



Smart 80 ● 7,5 kW

P. 64



A+

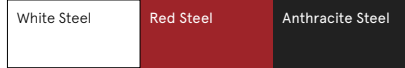
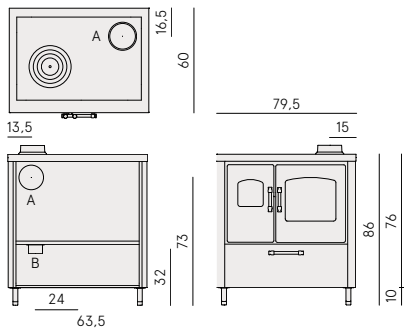

7,5 kW	9,4 kW	180 m³	2,1 kg	85,5 %	L 33 cm P 42 cm H 29 cm	L 17,2 cm H 16,7 cm
4 cm	152 kg	L 33 cm	A	B		

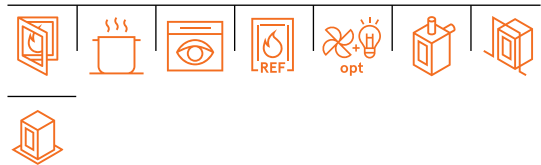

European standards BImSchV 2015 Regensburg München
Stuttgart Aachen EN 12815:2001/A1:2004/AC:2007
CE Certificate model name: SMART 80, SMART 80V, SMART 80S, SMART 80VS



Kook 60 4.0 ● 6,2 kW

P. 66



A+

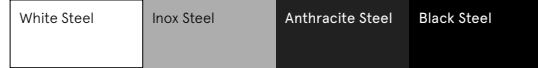
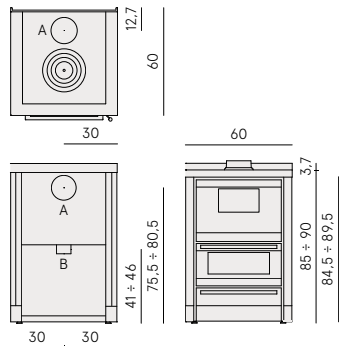

6,2 kW	7,4 kW	149 m³	1,7 kg/h	84,1 %	L 37 cm P 34 cm H 16,5 cm	L 26,1 cm H 14,4 cm
4 cm	121,6 kg	L 33 cm	A	B		



European standards Art. 15A B-VG 2015 BImSchV 2015 Regensburg München
Stuttgart Aachen EN 12815:2001/A1:2004/AC:2007
CE Certificate model name: KOOK60 4.0, KOOK60 4.0V



Kook 70 4.0 ● 6,2 kW

P. 66



A+

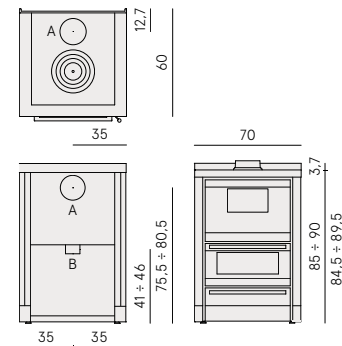

6,2 kW	7,4 kW	149 m³	1,7 kg	84,1 %	L 37 cm P 34 cm H 16,5 cm	L 26,1 cm H 14,4 cm
4 cm	128,1 kg	L 33 cm	A	B		



Art. 15A B-VG 2015 BImSchV 2015 Regensburg München
Stuttgart Aachen EN 12815:2001/A1:2004/AC:2007
CE Certificate model name: KOOK70 4.0



Kook 80 ● 7,5 kW

P. 66



A+

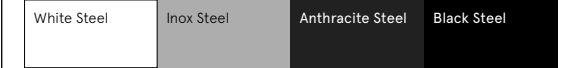
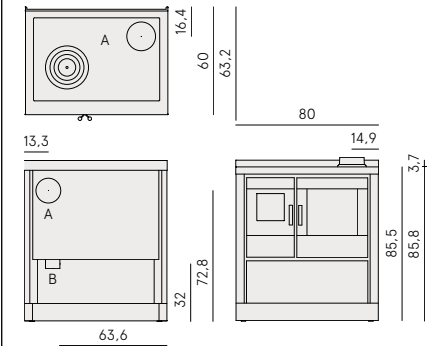

7,5 kW	9,5 kW	180 m³	2,2 kg	82,5 %	L 33 cm P 42 cm H 29 cm	L 17,2 cm H 16,7 cm
4 cm	138,2 kg	L 33 cm	A	B		



European standards Art. 15A B-VG 2015 BImSchV 2015 Regensburg München
Stuttgart Aachen EN 12815:2001/A1:2004/AC:2007
CE Certificate model name: KOOK80, KOOK80V



Kook 90 4.0 ● 7,5 kW

P. 66



A+

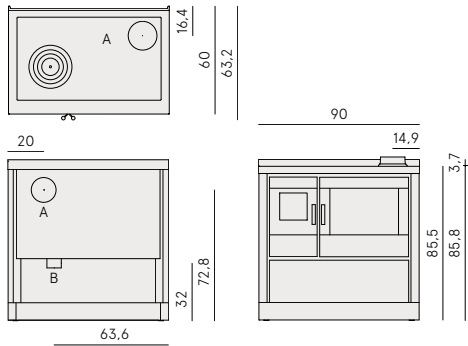

White Steel	Inox Steel	Anthracite Steel	Black Steel
-------------	------------	------------------	-------------

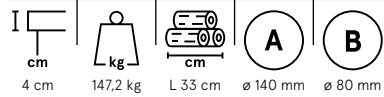
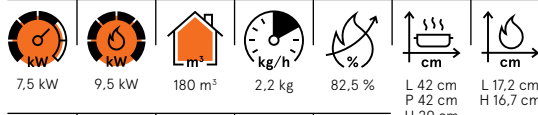

European standards Art. 15A B-VG 2015
 BImSchV 2015
 Regensburg
 München

Stuttgart
 Aachen
 EN 12815:2001/
 A1:2004/AC:2007

CE
 Certificate model name:
 KOOK90 4.0
 KOOK90V 4.0



Kook 67 4.0 ● 6,2 kW

P. 66



A+

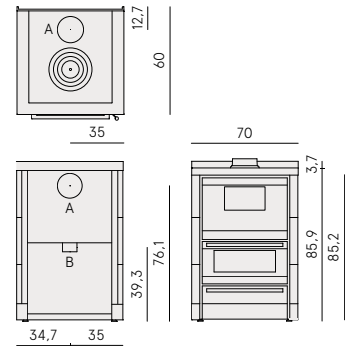

Ivory Majolica	Red Majolica
White Steel	Red Steel

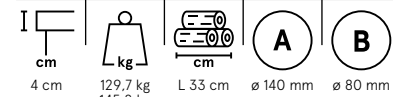
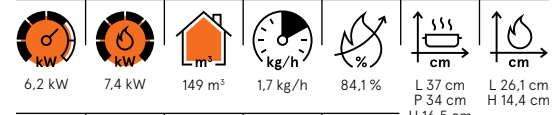

European standards Art. 15A B-VG 2015
 BImSchV 2015
 Regensburg
 München

Stuttgart
 Aachen
 EN 12815:2001/
 A1:2004/AC:2007

CE
 Certificate model name:
 KOOK67 4.0



Kook 87 ● 7,5 kW

P. 66



A+

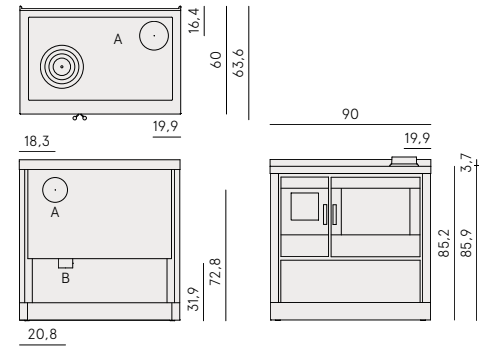

Ivory Majolica	Red Majolica
White Steel	Red Steel

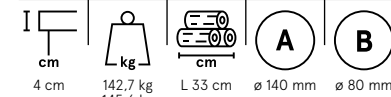
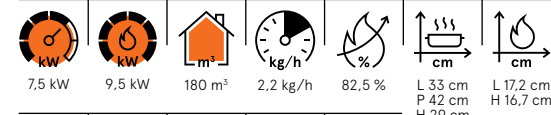

European standards Art. 15A B-VG 2015
 BImSchV 2015
 Regensburg
 München

Stuttgart
 Aachen
 EN 12815:2001/
 A1:2004/AC:2007

CE
 Certificate model name:
 KOOK87



Graphic design
Metodo studio

Rendering
Metaverso

Photo
Marina Caneve
(p.6)

Printing
Imoco Group

Cadel S.r.l
Via Foresto sud, 7
31025 Santa Lucia di Piave
(TV) Italy

cadelsrl.com



cod.87210024 06/2021

CADEL

cadelsrl.com