

Catalogo prodotti

Product catalogue
Catalogue de produits
Produktkatalog



CADEL









Il calore al centro

Features

Tecnologia / Technology / Technologie / Technologie

	UPS Ready Connessione batteria esterna External battery connection Connexion Batterie externe Externer Batterieanschluss		Flexit Flessibilità di installazione Flexibility of installation Flexibilité de l'installation Flexibilität der Installation		Go Fast Accensione rapida Faster pellet ignition Allumage plus rapide Schnellere Zündung
	Airtech Braciere autopulente Automatic brazier cleaning Brasero autonettoyant Selbstreinigende Brennschale		Idrotech Braciere autopulente Automatic brazier cleaning Brasero autonettoyant Selbstreinigende Brennschale		Valvola anti-fumo Anti-smoke valve Valve anti-fumée Rauchgasklappe
	5 stelle D.M. 186 Garantisce emissioni di polveri ridotte dell'80% rispetto agli apparecchi che hanno ottenuto 1 stella		4 stelle+ 4 stelle D.M. 186 ma con emissioni polveri da 5 stelle PP <=15(mg/Nm³)		Uscita concentrica integrata Integrated concentric outlet Sortie concentrique intégrée Integrierter konzentrischer Auslass (80 - 130 mm)
	Kit concentrico (opzionale) Concentric flue kit (optional) Kit concentrique (optionnel) Kit für konzentrisches Ableitungssystem (optional)		Camera stagna Sealed chamber Chambre étanche Hermetische Brennkammer		Braciere in ghisa Cast iron burning pot Brasero en fonte Brennschale aus Gusseisen
	Porta in ghisa Cast iron door Porte en fonte Gusseisentür		Interno in refrattario Refractory stone Intérieur réfractaire Feuerraum aus Schamotte		Interno in ghisa Cast iron inner Intérieur en fonte Feuerraum aus Gusseisen
	Magic Glass Vetro oscurato a stufa spenta Darkened glass when the stove is off Vitre obscurcie si poele éteint Getöntes Glas wenn ausgeschaltet		Shield Scocca senza saldature Shell without welding Coque sans soudure Körper ohne Schweißen		Vista sul forno View on the oven Vue sur le four Sicht des Backofens
	Cucinare Cooking Cuisiner Kochen		Telecomando con termostato (opzionale) / Remote control with therm. (optional) / Téléc. avec thermostat (opt.) / Fernbedienung mit thermostat(optional)		Wi-Fi e Bluetooth integrati Integrated Wi-Fi and Bluetooth Wi-Fi et Bluetooth intégré Integriertes WLAN und Bluetooth
	Comfort mode Massima silenziosità Maximum silence Maximum de silence Sehr leisen Betrieb		Ventilazione + luce (opzionale) Ventilation + light kit (optional) Ventilation + éclairage (optionnel) Lüftung kit + Beleuchtung (optional)		Ventilazione Ventilation Ventilation Lüftung
	Kit compl. Idro riscaldamento + acqua sanit. / Complete kit heat. + domestic water / Kit compl. hydro chauffage + eau sanitaire / Komplet-Set Hydro Heizung + Brauchwasser		Programmazione giornaliera settimanale / Daily weekly programming / Programmation journalière hebdomadaire / Programmierung Tag - Woche		Sensore di temperatura aria Air temperature sensor Capteur de température de l'air Temperaturfühler
	Sensore di temperatura acqua Water temperature sensor Capteur de température de l'eau Wassertemperaturfühler		Collegamento termostato esterno Connection to the external therm. Connexion du thermostat externe Anschluss an Raumthermostat		Kit canalizzazione (opzionale) Ducting kit (optional) Kit conduits de canalisation (optionnel) Kit für Kanalisierung (optional)
	Canalizzazione 1 motore indip. Duction with 1 indep. motor Conduits d'aération avec 1 moteur indép. / Kanalisierung mit 1 unabhängigen Luftgebläse		Canalizzazione 2 motori indipendenti Duction with 2 indep. motors Conduits d'aération avec 2 moteurs indép. / Kanalisierung mit 2 unabhängigen Luftgebläsen		Collegamento all'impianto di riscaldamento / Conn. to the heating system / Raccordement avec installation de chauffage / Anschluss zu Heizungssystem
	Kit idraulico incluso Hydraulic kit included Kit hydraulique inclus Hydrauliksatz enthalten				

Modalità d'installazione / Installation mode / Mode d'installation / Einbaubedingungen

	Scarico fumi superiore, posteriore e laterale / Upper, back and lateral exhaust / Sortie fumées supérieure, postérieure et latérale / Abgasstutzen Hinten, Seitlich, Oben		Scarico fumi superiore e posteriore Upper and back exhaust Sortie fumées supérieure et postérieure Abgasstutzen Hinten u. Oben		Scarico fumi superiore Upper exhaust Sortie fumées supérieure Abgasstutzen Oben
	Scarico fumi superiore (opzionale) Upper exhaust (optional) Sortie fumées supérieure (optionnel) Abgasstutzen (optional)		Scarico fumi posteriore Back exhaust Sortie fumées postérieure Abgasstutzen Hinten		Scarico fumi laterale Lateral exhaust Sortie fumées latérale Abgasstutzen Seitlich
	Canalizzazione superiore e posteriore Top and rear ducting Canalisation supérieure et post. Obere und hintere Kanalisierung		Installazione incassata Built-in Encastrable Zum Einbau		Installazione libera Free Standing Pose libre Freistehend

Catalogo prodotti

Product catalogue
Catalogue de produits
Produktkatalog

Spirit 5
● 5,1 kW
P. 16



Sound 5/7
● 5,5/7 kW
P. 18



Hublot 6
● 6 kW
P. 20



Magritte 6
● 6 kW
P. 22



Cristal 6
● 5,5 kW
P. 24

New



Cristal 7
● 7 kW
P. 26



Quasimodo 9
● 9 kW
P. 40



Zefiro 9
● 9 kW
P. 42



Frame 9
● 9 kW
P. 44



Shell 9
● 9,1 kW
P. 46



**Cristal 9/
Plus 9**
● 8,5 kW
P. 48



**Cristal 9
Airtech/Air**
● 8,5 kW
P. 50

Upgrade



Prince 11/Plus 11
● 10,5 kW
P. 64



Kobe 11/Plus 11
● 10,5 kW
P. 66



Fenice 11/Plus 11
● 10,5 kW
P. 68



Eclipse Plus 11
● 10,5 kW
P. 70



Atena Plus 12/14
● 12/13,7 kW
P. 72



Mithos Plus 12/14
● 12/13,7 kW
P. 74



Smart 60/80
● 6,5/7,5 kW
P. 88



Kook 60/80/90
● 6,2/ 7,5 kW
P. 90



Grace 7
● 6,9 kW
P. 28

Upgrade



Baggy 7
● 6,9 kW
P. 30

New



Bold 7
● 7 kW
P. 32

New



Perla 7
● 7 kW
P. 34



Sweet 7
● 7 kW
P. 36



Ponente 7
● 7 kW
P. 38



Spin Plus 9
● 8,5 kW
P. 52

Upgrade



Icon Plus 9
● 8,5 kW
P. 54



Luce Plus 9
● 8,5 kW
P. 56



Elle Plus 9
● 8,5 kW
P. 58



Wall Plus 10
● 10 kW
P. 60



Tile Plus 10
● 10 kW
P. 62



River idro 18/24
● 17,7/24,2 kW
P. 76



River Idro 16/23
● 16,1/22,4 kW
P. 78



Saturno 16/24
● 18/24,7 kW
P. 80



Maya Idro 16/24
● 16,1/22,4 kW
P. 82



Hublot 7/8
● 7/7,5 kW
P. 84



Spin 8/9
● 8/9 kW
P. 86

New



Pellet Air

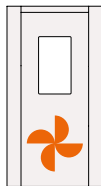

Cadel offre una gamma completa di stufe a pellet ventilate dotate di camera stagna per un maggior rendimento e minor consumo. Tutti i modelli di stufe Pellet Air sono certificati Classe Energetica A+, 4 stelle Aria Pulita™ o 5 stelle, 7 stelle Flamme Verte e sono riconosciuti come idonei a ricevere il rimborso Conto Termico.

Cadel offers a comprehensive range of ventilated air pellet stoves with a sealed chamber for greater efficiency and reduced consumption. All Pellet Air Stove models are conform with the EcoDesign 2022 directives.

Cadel propose une gamme complète de poêles à granulés à air ventilé équipés d'une chambre étanche pour un meilleur rendement et une moindre consommation. Tous les modèles de poêles Pellet Air sont certifiés 7 étoiles Flamme Vert et sont reconnus comme éligibles au crédit d'impôt. En outre, un an après leur introduction, ils sont référencés CSTB.

Cadel bietet eine vollständige Palette von Pelletöfen mit Gebläse und abgedichteter Brennkammer zur Gewährleistung von höherer Leistung und geringerem Verbrauch. Alle Pelletofen-Modelle der Linie Air sind Bimsch 2015 (Regensburg, München, Stuttgart, Aachen) und Klima Energiefonds zertifiziert.

Pellet Air Plus

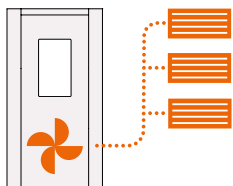

Per riscaldare più ambienti della casa in modo economico e pratico, la stufa a pellet canalizzabile Air Plus di Cadel è lo strumento ideale. Grazie al sistema di canalizzazione è possibile distribuire il calore rapidamente e in modo omogeneo anche in altre stanze. Tutti i modelli di stufe Pellet Air Plus sono certificati Classe Energetica A+, 4 o 5 stelle AriaPulita™, 7 stelle Flamme Verte e sono riconosciuti come idonei a ricevere il rimborso Conto Termico.

A Cadel Air Plus ductable pellet stove is the ideal tool to heat up several rooms in the house in a cost-effective and convenient way. Thanks to its ducting, you can distribute heat quickly and evenly in other rooms as well. All Pellet Air Plus Stove models are conform with the EcoDesign 2022 directives.

Pour chauffer plusieurs pièces de la maison de manière économique et pratique, le poêle à granulés canalisable Air Plus de Cadel est l'instrument idéal. Grâce au système de canalisation, il est possible de distribuer la chaleur rapidement et de façon homogène dans d'autres pièces aussi. Tous les modèles de poêles Pellet Air plus sont certifiés 7 étoiles Flamme Vert et sont reconnus comme éligibles au crédit d'impôt. En outre, un an après leur introduction, ils sont référencés CSTB.

Der kanalisierbare Pelletofen Air Plus von Cadel ist die ideale Lösung, um auf sparsame und praktische Weise mehrere Wohnräume zu erwärmen. Die Kanalisierung ermöglicht es, die Wärme rasch und gleichmäßig auch auf andere Räume zu verteilen. Alle Pelletofen-Modelle der Linie Air Plus sind Bimsch 2015 (Regensburg, München, Stuttgart, Aachen) und Klima Energiefonds zertifiziert.

Pellet Hydro

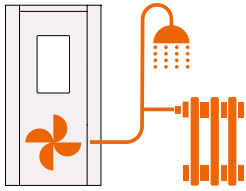

Le termostufe Cadel sono la soluzione ottimale per l'impianto di riscaldamento domestico, riscaldando rapidamente l'acqua dei termosifoni. Sono pratiche ed economiche ed uniscono la funzionalità ad un'estetica accattivante. Alcuni modelli sono disponibili nella versione H₂O: dotate di un apposito kit queste termostufe a pellet possono produrre acqua calda sanitaria.

Cadel thermostoves are an excellent solution for domestic heating systems, since they quickly heat water in the radiators, they are convenient and cost-effective, and combine functionality with a charming design. Some models are available in the H₂O version: equipped with a special kit, these pellet thermostoves can produce domestic hot water.

Les thermo-poêles Cadel sont une excellente solution pour le chauffage domestique, car ils chauffent rapidement l'eau des radiateurs, ils sont pratiques et économiques et allient fonctionnalité et aspect attrayant. Certains modèles sont disponibles dans la version H₂O : équipés d'un kit spécial, ces thermo-poêles à pellets peuvent produire de l'eau chaude sanitaire.

Die Thermoöfen von Cadel sind eine optimale Lösung für Wohnungsheizanlagen. Sie sorgen für eine schnelle Erwärmung des Wassers in den Heizkörpern, sind praktisch und wirtschaftlich und verbinden Funktionalität mit attraktiver Ästhetik. Einige Modelle sind auch in der Version H₂O erhältlich: Mit einem speziellen Bausatz ausgestattet können diese Pelletöfen auch das Warmwasser liefern.

Wood

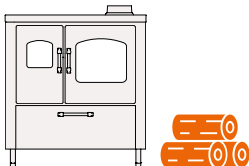

Conformi alle normative ambientali più severe, i prodotti a legna Cadel a libera installazione e da incasso uniscono il riscaldamento domestico, la versatilità installativa e l'estetica elegante. Grazie ad attente soluzioni costruttive, questi prodotti non necessitano di ulteriori kit per l'inserimento all'interno di un mobile cucina e le finiture curate permettono di poterle installare liberamente in qualsiasi ambiente.

Compliant with the strictest environmental regulations, Cadel's free and recessed installation wood products combine home heating with versatile installation and elegant aesthetics. Thanks to meticulous construction solutions, these products do not require additional kits for insertion in kitchen units and are well finished, which allows them to be easily installed in any room.

En conformité avec les réglementations environnementales les plus strictes, les produits à bois Cadel autonomes et encastrables allient le chauffage domestique, la polyvalence d'installation et l'esthétique élégante. Grâce à des solutions de construction soignées, ces produits ne nécessitent pas de kits supplémentaires pour l'insertion dans un meuble de cuisine, et les finitions raffinées permettent de les installer librement dans n'importe quelle pièce.

Die Holzgefeuerten Geräte von Cadel zur freistehenden Installation und zum Einbau vereinen in sich das Heizen der Wohnung, die Flexibilität bei der Installation und ein elegantes Design. Dank ihrer besonderen Bauart ist bei diesen Geräten kein zusätzlicher Bausatz für den Einbau in eine Küchenzeile erforderlich, und durch die edlen Oberflächen ist die Installation freistehend in jedem beliebigen Raum möglich.



Il piacere della legna

La nostra gamma si arricchisce con l'aggiunta delle stufe a legna, che rendono l'atmosfera sempre accogliente.

- Protagonista in ogni ambiente, grazie a linee semplici ed eleganti.
- Autenticità del calore, godendo dell'esperienza visiva e sonora di un fuoco scoppiettante.
- Possibilità di scelta tra cucine e stufe a legna, disponibili anche in versione ventilata, per adattarsi ad ogni esigenza.

Our range is enriched by wood stoves, which create a consistently welcoming atmosphere.

- Perfect match to any space, thanks to simple and elegant lines.
- Genuine warmth, enjoying the vision and sound of a crackling fire.
- Our wood models are also available in a ventilated version, to suit every need.

Notre gamme est enrichie de poêles à bois qui donnent toujours une accueillante atmosphère.

- Protagoniste dans chaque pièce, grâce à des lignes simples et élégantes.
- Authenticité de la chaleur, en profitant de l'expérience visuelle et sonore d'un feu crépitant.
- Nos modèles à bois sont également disponibles en version ventilée, pour s'adapter à chaque besoin.

Unser Sortiment wird durch die Zugabe von Holzöfen bereichert, die eine stets einladende Atmosphäre schaffen.

- Protagonist in jedem Raum, dank einfacher und eleganter Linien.
- Authentische Wärme, die visuelle und akustische Erfahrung eines knisternden Feuers genießen.
- Auswahl zwischen Holzherden und -öfen, auch in einer belüfteten Version erhältlich, um allen Anforderungen gerecht zu werden.

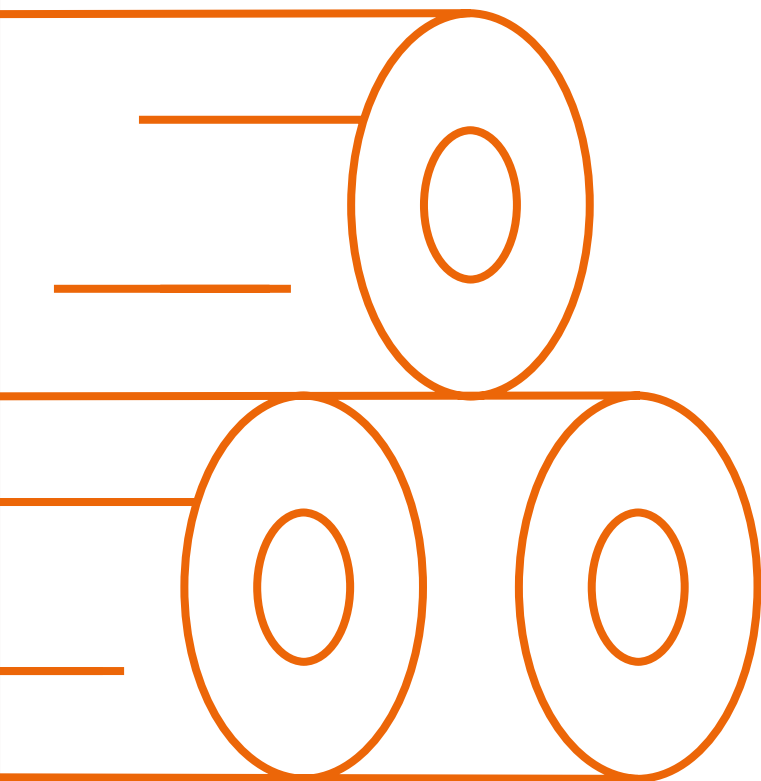

Tecnologie

Airtech



L'innovativo **braciere autopulente** della linea Pellet Air/Air Plus svolge le necessarie operazioni di pulizia braciere in modo automatico, garantendo sempre l'ottimale funzionamento della stufa e diminuendo la frequenza della pulizia manuale.

The innovative **self-cleaning brazier** of the Pellet Air/Air Plus line performs the necessary brazier cleaning automatically, always guaranteeing optimal operation of the stove and reducing the frequency of manual cleaning.

Le **brasero autonettoyant** innovant de la ligne Pellet Air/Air Plus effectue automatiquement le nettoyage nécessaire du brasero, garantissant toujours un fonctionnement optimal du poêle et réduisant la fréquence des nettoyages manuels.

Die innovative **selbstreinigende Brennschale** der Linie Pellet Air/Air Plus führt die notwendige Reinigung der Brennschale automatisch durch, so dass ein optimaler Betrieb des Ofens stets gewährleistet ist und die Häufigkeit der Reinigung von Hand reduziert wird.

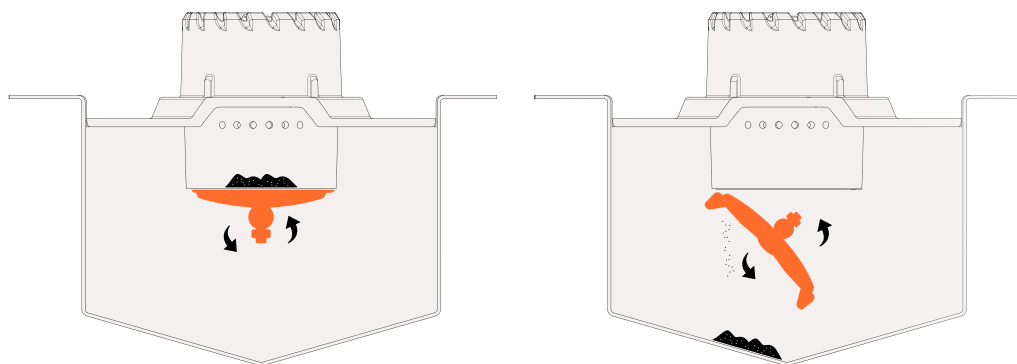

Idrotech



Idrotech è l'innovativo sistema di **pulizia automatica** della linea Pellet Idro, che asporta automaticamente i depositi di cenere nel braciere evitando la pulizia giornaliera manuale del focolare. La cenere viene raschiata meccanicamente a intervalli regolari, rilevando eventuali intasamenti. In questo modo la combustione è sempre perfetta ed efficiente.

Idrotech is the innovative **automatic cleaning system** of the Pellet Idro line, which automatically removes ash deposits in the brazier, avoiding daily manual cleaning of the firebox. The ash is mechanically scraped at regular intervals, detecting any clogging. In this way, combustion is always perfect and efficient.

Idrotech est le système innovant de **nettoyage automatique** de la ligne Pellet Idro, qui élimine automatiquement les dépôts de cendres dans le brasero, évitant ainsi le nettoyage manuel quotidien du foyer. Les cendres sont raclées mécaniquement à intervalles réguliers, ce qui permet de détecter tout colmatage. De cette façon, la combustion est toujours parfaite et efficace.

Idrotech ist das innovative **automatische Reinigungssystem** der Linie Pellet Idro, das die Ascheablagerungen im Feuerraum automatisch entfernt und die tägliche Reinigung von Hand der Brennschale überflüssig macht. Die Asche wird in regelmäßigen Abständen mechanisch abgeschabt, um eventuelle Verstopfungen zu beseitigen. Auf diese Weise ist die Verbrennung immer perfekt und effizient.

Go Fast

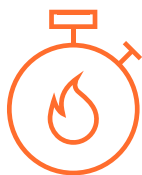

Sistema costituito da una candeletta/resistenza in ceramica che garantisce un'**accensione più rapida del pellet** e un consumo di elettricità inferiore rispetto alle tradizionali resistenze in metallo. Questa tipologia di resistenza ha inoltre una maggiore durata nel tempo grazie alla migliore tenuta all'ossidazione e alla corrosione naturale e chimica.

System consisting of a ceramic type glow plug/resistor that guarantees **faster pellet ignition** and lower electricity consumption than the conventional metal resistor. This type of resistor also has a longer service life thanks to better resistance to oxidation and to natural and chemical corrosion.

Système constitué d'une bougie de préchauffage/résistance de type céramique qui garantit un **allumage plus rapide du pellet** et une consommation d'électricité inférieure par rapport aux résistances traditionnelles en métal. Ce type de résistance a par ailleurs une plus grande durée dans le temps grâce à la meilleure résistance à l'oxydation et à la corrosion naturelle et chimique.

Das System besteht aus einer keramischen Zündkerze/Widerstand, die eine **schnellere Zündung der Pellets** und einen geringeren Stromverbrauch als herkömmliche Metallwiderstände gewährleistet. Diese Art von Widerstand hat zudem eine längere Lebensdauer, da sie besser gegen Oxidation und natürliche und chemische Korrosion beständig ist.

Tecnologie

Flexit



La tecnologia Flexit garantisce un'ottima **flessibilità in termini di installazione**, sia per quanto concerne l'uscita dei fumi (possono essere posteriori, superiori, superiori-concentriche) che quelle d'aria calda canalizzabile (posteriori o superiori).

The Flexit technology guarantees excellent **flexibility in terms of installation**, with regards to smoke outlet – which can be rear, top, top-concentric – as well as with regards to ductable hot air (rear or top).

La technologie Flexit garantit une excellente **flexibilité en termes d'installation**, aussi bien en ce qui concerne les sorties des fumées (elles peuvent être postérieures, supérieures, supérieures-concentriques) que celles de l'air chaud canalisable (postérieures ou supérieures).

Die Flexit-Technologie bietet eine hervorragende **Flexibilität bei der Installation**, sowohl hinsichtlich des Rauchgasabzugs (hinten, oben, oben-konzentrisch) als auch bezüglich des kanalisierbaren Auslasses von Warmluft (hinten oder oben).

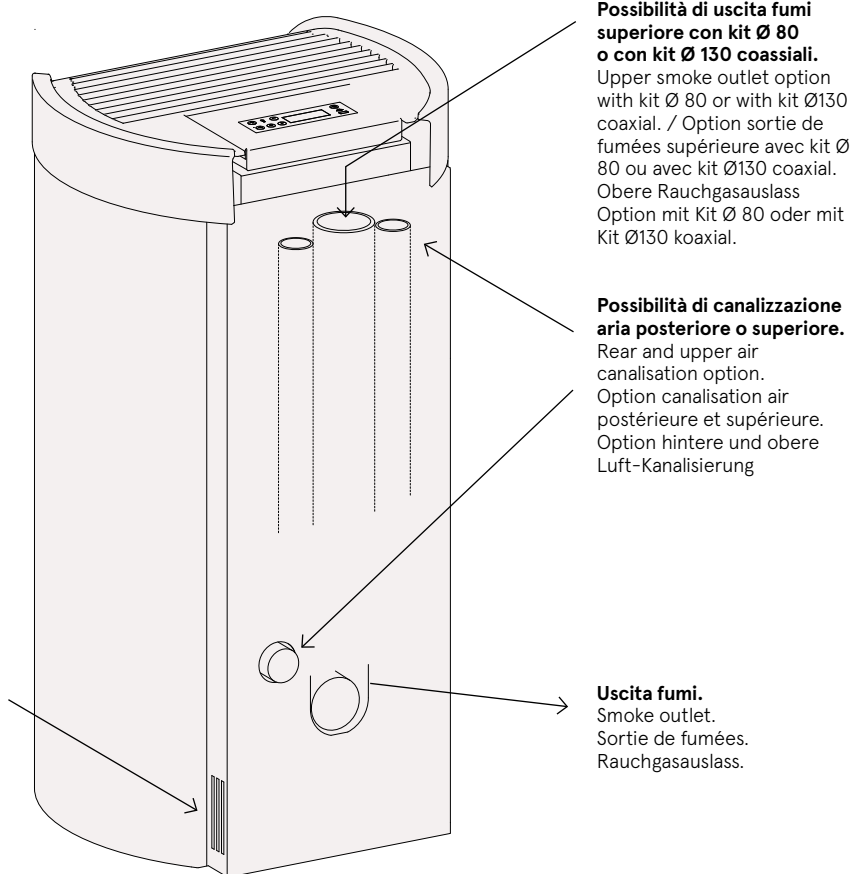

Possibilità di uscita fumi superiore con kit Ø 80 o con kit Ø 130 coassiali.

Upper smoke outlet option with kit Ø 80 or with kit Ø130 coaxial. / Option sortie de fumées supérieure avec kit Ø 80 ou avec kit Ø130 coaxial. Obere Rauchgasauslass Option mit Kit Ø 80 oder mit Kit Ø130 koaxial.

Possibilità di canalizzazione aria posteriore o superiore.

Rear and upper air canalisation option. Option canalisation air postérieure et supérieure. Option hintere und obere Luft-Kanalisierung

Uscita fumi.

Smoke outlet. Sortie de fumées. Rauchgasauslass.

Sui modelli Plus ventilazione laterale di serie. / Standard side ventilation on Plus Models. Ventilation latérale standard sur les modèles Plus. Standard seitliche Belüftung bei Plus Modellen.

Ups ready

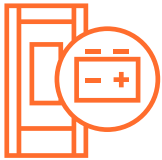

Accessorio per predisporre la stufa al **collegamento con una batteria di backup esterna** (non inclusa), per garantire un'alimentazione continua e la massima protezione durante lo spegnimento della stufa in caso di blackout.

Accessory to prepare the stove for **connection to an external buffer battery** (not included), to ensure continuous power supply and maximum protection during stove shutdown in the event of a power failure.

Accessoire permettant de préparer les poêles au **branchement à une batterie de secours externe** (non incluse), afin de garantir une alimentation continue et une protection maximale pendant l'arrêt du poêle en cas de panne de courant.

Zubehör, um den Ofen für den **Anschluss an eine externe Pufferbatterie** (nicht im Lieferumfang enthalten) vorzubereiten, um eine kontinuierliche Stromversorgung und maximalen Schutz beim Abschalten des Ofens im Falle eines Stromausfalls zu gewährleisten.

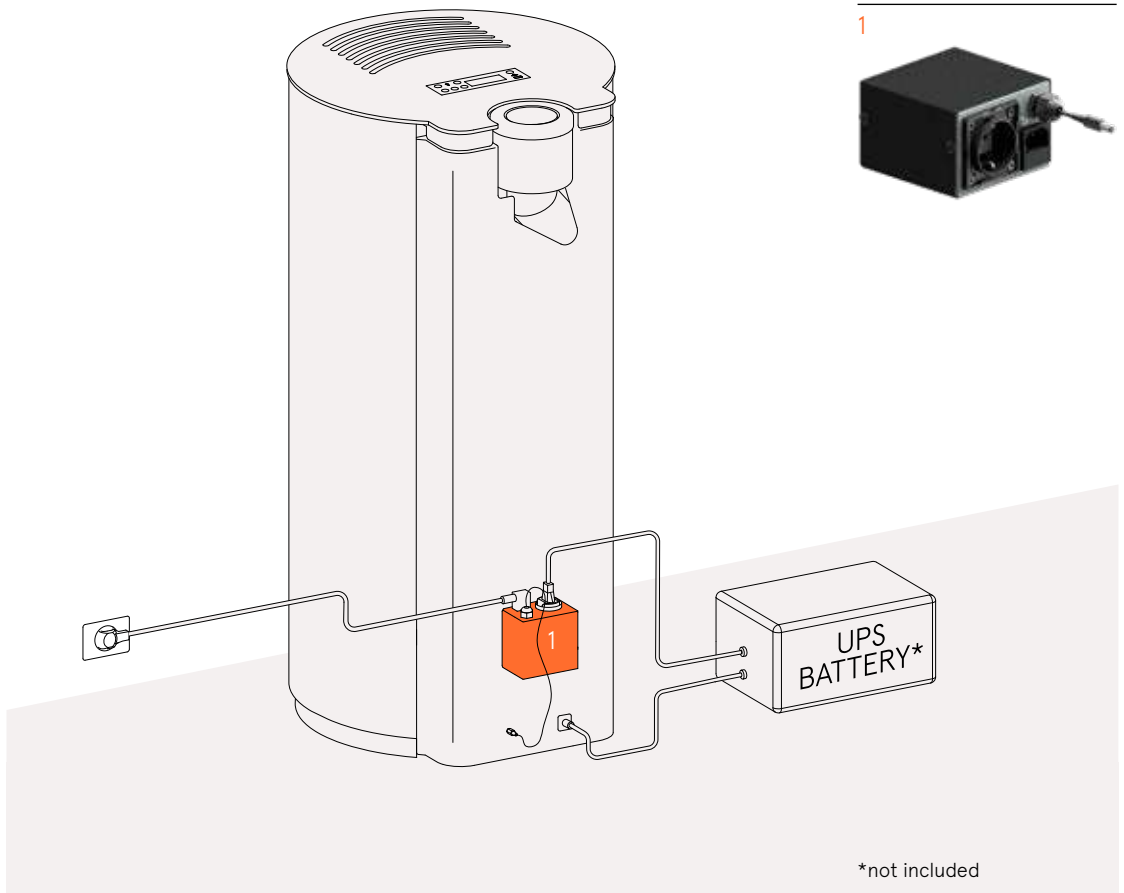

Plus Cadel

Comfort mode



Spegne automaticamente i ventilatori quando la stufa è al minimo (potenza 1), per garantire la **massima silenziosità**. La tecnologia Comfort Mode è attiva di default su tutte stufe. Nei modelli delle linee Air Plus e Idro questa funzione è disattivabile direttamente dal menù del display.

It automatically switches off the fans when the stove is idling (power 1), to ensure **maximum silence**. Comfort Mode technology is active by default on all stoves. In models of the Air Plus and Idro lines, this function can be deactivated directly from the display menu.

Il éteint automatiquement les ventilateurs lorsque le poêle fonctionne au ralenti (puissance 1), afin de garantir un **maximum de silence**. La technologie Comfort Mode est activée par défaut sur tous les poêles. Dans les modèles des lignes Air Plus et Idro, cette fonction peut être désactivée directement à partir du menu d'affichage.

Er schaltet die Gebläse automatisch ab, wenn der Ofen auf Mindestleistung läuft (Leistung 1), um einen sehr **leisen Betrieb** zu gewährleisten. Die Technologie Comfort Mode ist bei allen Öfen standardmäßig aktiviert. Bei den Modellen der Linien Air Plus und Idro kann diese Funktion direkt über das Displaymenü deaktiviert werden.

Ventilatori indipendenti



Grazie al sistema di canalizzazione dell'aria, con le stufe Air Plus è possibile distribuire il **calore in modo omogeneo in più stanze**. A seconda delle esigenze abbiamo stufe canalizzabili a due o tre uscite: tutti i ventilatori di canalizzazione possono essere gestiti in modo autonomo.

Independent fans

Thanks to the air ducting system of the Air Plus stoves, heat can be evenly distributed in several rooms. Depending on your needs, we have ductable stoves with two or three outlets: all fans can be controlled separately.

Ventilateurs indépendants

Grâce au système de canalisation de l'air, les poêles Air Plus permettent de distribuer la chaleur de façon homogène dans plusieurs pièces. En fonction des besoins, il est possible d'opter pour un poêle canalisable à deux ou trois sorties : tous les ventilateurs peuvent être gérés de manière autonome.

Unabhängige Gebläse

Die Kanalisierung ermöglicht es bei den Air Plus Öfen, die Wärme rasch und gleichmäßig in mehreren Räumen zu verteilen. Je nach Bedarf bieten wir Öfen mit zwei oder drei Luftauslässen an: Hier können alle Gebläse unabhängig gesteuert werden.

Camera stagna



Stufe a pellet **totalmente ermetiche** rispetto all'ambiente d'installazione: prelevano l'aria di combustione dall'esterno e non dal locale in cui sono installate. Meno emissioni, più sicurezza, maggior rendimento.

Sealed chamber

Pellet stoves that are completely sealed in relation to the room of installation: they draw combustion air directly from outdoors and not from the room they are installed in.

- Fewer emissions
- More safety
- Greater efficiency

Chambre étanche

Ces poêles à pellets sont parfaitement hermétiques par rapport à l'environnement d'installation : ils prélèvent l'air de combustion de l'extérieur directement et non pas du local dans lequel ils sont installés.

- Moins d'émissions
- Plus de sécurité
- Meilleur rendement

Hermetische Brennkammer

Vollkommen gegen die Installationsumgebung abgedichtet: Die Verbrennungsluft wird direkt von außen angesaugt, nicht aus dem Raum, in dem der Ofen installiert ist.

- Weniger Emissionen
- Mehr Sicherheit
- Höherer Wirkungsgrad

5 stelle



Cadel rispetta lo schema italiano di **certificazione D.M. 186**, che valuta le stufe in base al rendimento energetico e alle emissioni prodotte. Raggiungono la classificazione a 5 stelle secondo il D.M. 186, le stufe, gli inserti a pellet e prodotti a legna che garantiscono emissioni di polveri ridotte dell'80% rispetto agli apparecchi che hanno ottenuto 1 stella.

Cadel complies with the Italian **M.D. 186 certification** scheme, which evaluates stoves according to their energy efficiency and emissions. Stoves, pellet inserts, and wood products guaranteeing dust emissions reduced by 80% compared to 1-star appliances are awarded the 5-star classification in accordance with M.D. 186.

Cadel respecte les critères italiens de **certification D.M. 186**, qui évalue les poêles en fonction de leur efficacité énergétique et de leurs émissions. Les poêles, inserts à granulés et produits à bois qui garantissent des émissions de poussières réduites de 80 % par rapport aux appareils ayant obtenu 1 étoile obtiennent la classification 5 étoiles selon le Décret ministériel 186.

Cadel erfüllt die italienischen Anforderungen des Zertifizierungssystems nach dem italienischen **Ministerialerlass 186**, das Öfen nach deren Energieeffizienz und erzeugten Emissionen bewertet. Mit der 5-Sterne-Klassifizierung nach dem italienischen Ministerialerlass 186 garantieren Öfen, Pelleteinsätze und Holzprodukte eine Reduzierung der Staubemissionen um 80% im Vergleich zu 1-Stern-Geräten



● Wi-Fi & Bluetooth

Easy Connect Plus

Per una stufa sempre connessa e intelligente

Con l'app **Easy Connect Plus**, e le tecnologie **Wi-Fi** e **Bluetooth** integrate, puoi accendere, programmare, controllare e spegnere tutte le stufe CADEL direttamente dal tuo smartphone, ovunque tu sia. In una sola schermata puoi controllare e gestire le funzioni principali, impostando tempi e temperatura desiderata per ottimizzare i consumi e migliorare il comfort.

For a smart stove connected at all times

Thanks to the **Easy Connect Plus** app, and the built-in **Wi-Fi** and **Bluetooth** technologies, you can turn on, set up, control and turn off all CADEL stoves easily using your smartphone – wherever you are. From a single screen, you can access and control the main features and set on/off times and the desired temperature for optimal consumption and greater comfort

Pour un poêle toujours connecté et intelligent

Grâce à l'application **Easy Connect Plus** et aux technologies **Wi-Fi** et **Bluetooth** intégrés, vous pouvez allumer, programmer, contrôler et éteindre tous les poêles CADEL depuis votre smartphone, où que vous soyez. Une seule page vous permet de contrôler et gérer les fonctions principales, régler les durées et la température souhaitée, afin d'optimiser les consommations et améliorer le confort.

Für einen stets verbundenen und intelligenten Ofen

Mit der App **Easy Connect Plus** und den integrierten **WLAN** - und **Bluetooth**-Technologien können Sie alle Öfen von CADEL direkt von Ihrem Smartphone einschalten, programmieren, steuern und ausschalten, wo immer Sie sich gerade befinden. Von einer einzigen Ansicht aus können Sie die wichtigsten Funktionen steuern und verwalten und die Betriebszeiten und die gewünschte Temperatur einstellen. So können Sie den Verbrauch optimieren und den Wärmekomfort nach Ihren Wünschen gestalten.



Informazioni

Una panoramica sullo stato di funzionamento della stufa, in relazione alle funzioni e regolazioni attive.

Information

An overview of the stove's operating status in relation to active functions and adjustments.

Informations

Un aperçu de l'état de fonctionnement du poêle, en ce qui concerne les fonctions et réglages activés.

Informationen

Eine Übersicht über den Betriebsstatus des Ofens je nach den aktivierten Funktionen und Regulierungen.



Regolazioni

Regolazione potenza, temperatura ambiente, canalizzazione, ventilazione e Eco Stop. Nelle stufe idro controllo della temperatura dell'acqua per Caldaia e Puffer.

Adjustments

Power, room temperature, ducting, ventilation and Eco Stop adjustment. Boiler and Puffer water temperature can be controlled in hydro stoves.

Réglages

Réglage de la puissance, de la température ambiante, des canalisations, de la ventilation et de la fonction Eco Stop. Contrôle de la température de l'eau de la chaudière et du ballon tampon des poêles hydro.

Regulierungen

Regulierung der Leistung, der Raumtemperatur, der Luftkanalisierung und der Ventilation sowie Eco Stop. Bei den wasserführenden Öfen Temperaturkontrolle von Kessel und Pufferspeicher.

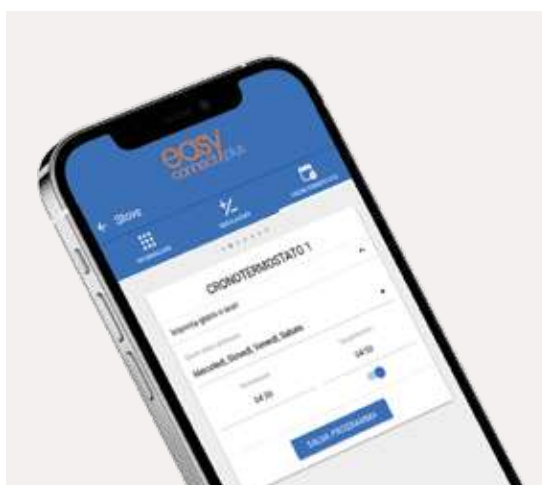

Cronotermostato

Programmazione per l'accensione e lo spegnimento della stufa in base alle esigenze di comfort.

Programmable thermostat

Programme the stove to switch on or off as needed for your comfort.









Thermostat programmable

Programmation pour allumer et éteindre le poêle en fonction des besoins de confort.

Zeitthermostat

Programmierung zum Ein- und Ausschalten des Ofens je nach gewünschtem WärmeKomfort.



 Classificazione 5 stelle (D.M.186)	 Wi-Fi Bluetooth*	 Comfort mode**	 Up. back. lat. (v. 5)
 Back. lateral (v. 5 FRANCE)	 Up (v. 5 Up)	 71/146	 12

* **Gestione tramite Wi-Fi e Bluetooth integrati.**
Control through integrated Wi-Fi and Bluetooth.
Gestion via Wi-Fi et Bluetooth intégrés.
Verwaltung über WLAN und integriertes Bluetooth.

** **Disattiva i ventilatori per garantire la massima silenziosità**
Deactivates stove fans, to guarantee maximum silence/Désactivez les ventilateurs afin de garantir le maximum de silence/Deaktivierung der Gebläse, um maximale Ruhe zu gewährleisten

5,1 kW





Spirit 5



Spirit 5 Up

Scopri le
caratteristiche
del prodotto
e il tuo risparmio
con il conto
termico

Spirit 5/5 Up



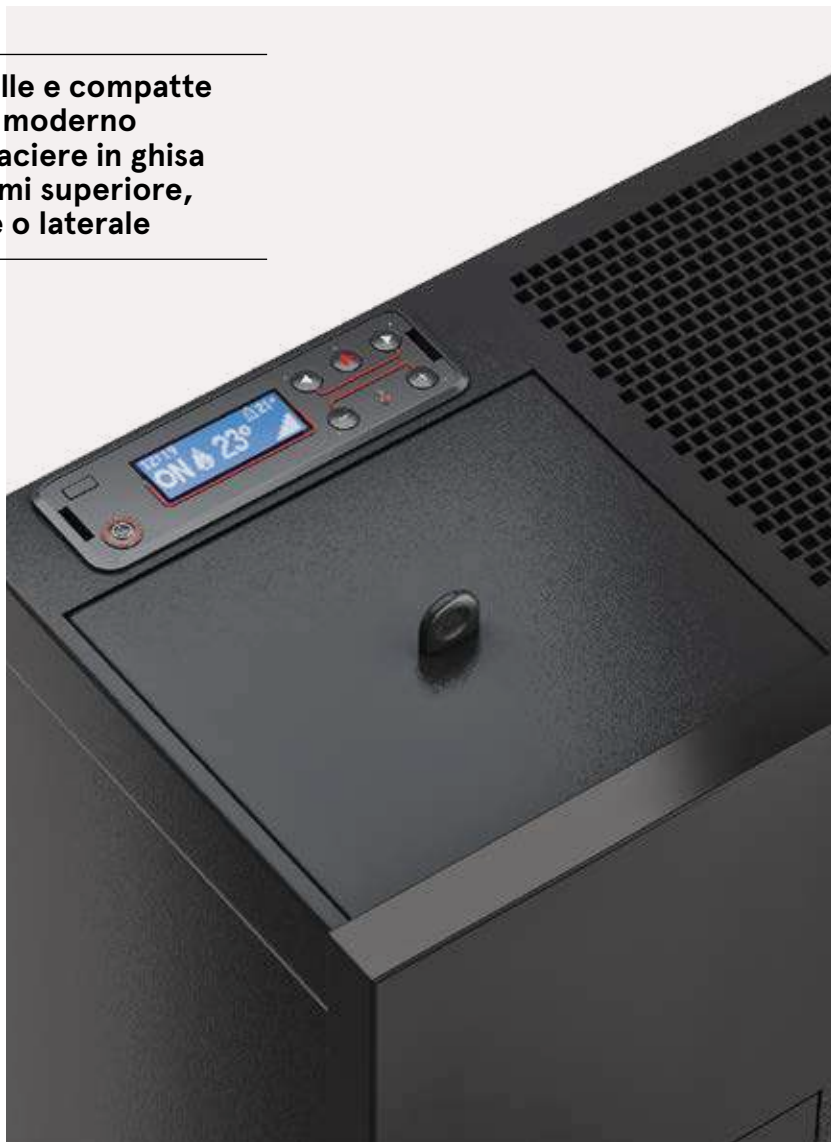





- **Forme snelle e compatte dal design moderno**
- **Porta e braciere in ghisa**
- **Scarico fumi superiore, posteriore o laterale**



- Slim and compact shapes with a modern design
- Cast iron door and burning pot
- Upper, back or lateral exhaust

- Formes élancées et compactes au design moderne
- Porte et brasero en fonte
- Sortie des fumées supérieure, postérieure ou latérale

- Schlanke und kompakte Formen mit modernem Design
- Tür und Brennschale aus Gusseisen
- Rauchgasabzug oben, hinten oder seitlich

			
Classificazione 5 stelle (D.M.186)	Classificazione 4+ stelle (D.M.186)	Wi-Fi Bluetooth*	Up (v. Up)
			
Back (v. Ps)	Magic glass**	71/157 (v. 5) 83/200 (v. 7)	11

*** Gestione tramite Wi-Fi e Bluetooth integrati.**
Control through integrated Wi-Fi and Bluetooth.
Gestion via Wi-Fi et Bluetooth intégrés.
Verwaltung über WLAN und integriertes Bluetooth.

**** Vetro oscurato Magic Glass a stufa spenta.**
Magic Glass tinted glass when the stove is off.
Vitre obscurcie Magic Glass lorsque le poêle est éteint.
Getönte Magic Glas Glasscheibe bei ausgeschaltetem Ofen.

5,5/
7 kW





Sound 5 Ps



Sound 7 Ps



Sound 5 Up-Twin



Sound 7 Up-Twin

Scopri le
caratteristiche
del prodotto
e il tuo risparmio
con il conto
termico

Sound 5/7

Ps/Up-Twin



-
- Stufa tonda dal design moderno
 - Top e base in ghisa
 - Vetro Magic Glass
-

- Round stove with a modern design
- Cast iron top and base
- Magic glass

- Poêle rond au design moderne
- Couvercle et base en fonte
- Vitre Magic Glass

- Runder Ofen mit modernem Design
- Topplatte und Sockel aus Gusseisen
- Magic-Glass-Glasscheibe

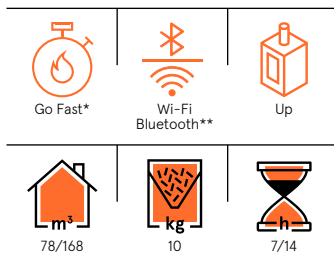

*** Candeletta di tipo ceramico che garantisce un'accensione più rapida del pellet.**
Glow plug that guarantees faster pellet ignition.
Bougie de préchauffage de type céramique qui garantit un allumage plus rapide du pellet.
Keramischen Zündkerze stand, die eine schnellere Zündung der Pellets.

**** Gestione tramite Wi-Fi e Bluetooth integrati.**
Control through integrated Wi-Fi and Bluetooth.
Gestion via Wi-Fi et Bluetooth intégrés.
Verwaltung über WLAN und integriertes Bluetooth.

6 kW





Scopri le
caratteristiche
del prodotto
e il tuo risparmio
con il conto
termico

- Small and compact pellet stove with a wide view of the flame
- Large 'porthole' door, top and feet made of cast iron
- Front ventilation
- It is perfect to be installed in an existing firebox
- Petit et compact, poêle à granulés a une large vue sur la flamme
- Grande porte à hublot, couvercle et pieds en fonte
- Ventilation frontale
- Parfait pour être installé dans une cheminée existante
- Kleiner und kompakter Pelletofen mit einer weite Sicht auf die Flamme
- Große 'Bullaugen'-Tür, Topplatte und Füße aus Gusseisen
- Frontale Gebläse
- Ist perfekt fürs Einbau in einem bestehenden Kamin

Hublot 6

Up-Twin

-
- **Piccola e compatta, con ampia visione della fiamma**
 - **Grande porta "oblò", top e piedini in ghisa**
 - **Ventilazione frontale**
 - **Perfetta per essere installata in un focolare esistente**
-





Go Fast*



Wi-Fi
Bluetooth**



Up



Back



m³
78/168



kg
10



h
7/14

*** Candeletta di tipo ceramico che garantisce un'accensione più rapida del pellet.**
Glow plug that guarantees faster pellet ignition.
Bougie de préchauffage de type céramique qui garantit un allumage plus rapide du pellet.
Keramischen Zündkerze stand, die eine schnellere Zündung der Pellets.

**** Gestione tramite Wi-Fi e Bluetooth integrati.**
Control through integrated Wi-Fi and Bluetooth.
Gestion via Wi-Fi et Bluetooth intégrés.
Verwaltung über WLAN und integriertes Bluetooth.

6 kW





Scopri le
caratteristiche
del prodotto
e il tuo risparmio
con il conto
termico

Magritte 6

- Stufa a pellet compatta e dal design contemporaneo
- La grande porta in ghisa esalta la visione del fuoco
- Porta, top, griglia e base in ghisa
- Ventilazione frontale
- Perfetta per essere installata in un focolare esistente



- Compact, contemporary-designed pellet stove
- The large cast-iron door enhances the view of the fire
- Door, top, grill and base are made of cast iron
- Front ventilation
- It is perfect to be installed in an existing firebox
- Poêle à granulés compact au design contemporain
- La grande porte en fonte met en valeur la vue sur le feu
- Porte, couvercle, grille et base sont en fonte
- Ventilation frontale
- Parfait à installer dans une cheminée existante
- Kompakten Pelletofen mit zeitgemäßem Design
- Die große Tür aus Gusseisen ermöglicht eine optimale Sicht auf das Feuer
- Tür, Topplatte, Grillrost und Füße sind aus Gusseisen
- Frontale Gebläse
- Ist perfekt fürs Einbau in einen bestehenden Kamin



Classificazione
5 stelle (D.M.186)



Wi-Fi
Bluetooth*



Back



73/154



11



8/18

* **Gestione tramite Wi-Fi e Bluetooth integrati.**
Control through integrated Wi-Fi and Bluetooth.
Gestion via Wi-Fi et Bluetooth intégrés.
Verwaltung über WLAN und integriertes Bluetooth.

5,5 kW





Scopri le
caratteristiche
del prodotto
e il tuo risparmio
con il conto
termico

- Solid cast iron door
- Frontal ventilation
- Daily programming also from your smartphone thanks to the Easy Connect Plus app

- Porte en fonte solide
- Ventilation frontale
- Programmation hebdomadaire également à partir de votre smartphone grâce à l'application Easy Connect Plus

- Massive Tür aus Gusseisen
- Frontale Ventilation
- Tägliche Programmierung auch über Ihr Smartphone dank der Easy Connect Plus App









Cristal 6

- Porta in solida ghisa
- Ventilazione frontale
- Programmazione giornaliera anche dal proprio smartphone grazie alla app Easy Connect Plus



opt



 Classificazione 5 stelle (D.M.186)	 Wi-Fi Bluetooth*	 Comfort mode**	 Up
 Back	 83/200	 15 12 (v. Up)	 9/25 7/20 (v. Up)

* **Gestione tramite Wi-Fi e Bluetooth integrati.**
Control through integrated Wi-Fi and Bluetooth.
Gestion via Wi-Fi et Bluetooth intégrés.
Verwaltung über WLAN und integriertes Bluetooth.

** **Disattiva i ventilatori per garantire la massima silenziosità.**
Deactivates stove fans, to guarantee maximum silence.
Désactivez les ventilateurs afin de garantir le maximum de silence.
Deaktivierung der Gebläse, um maximale Ruhe zu gewährleisten.

7 kW





Cristal 7



Cristal 7 Up

Scopri le
caratteristiche
del prodotto
e il tuo risparmio
con il conto
termico

Cristal 7/7 Up











- **Essenziale e funzionale**
- **Ottimo rapporto qualità prezzo**
- **Wi-Fi e bluetooth inclusi**



- Essential and functional
- Great value for money
- Wi-Fi and Bluetooth included

- Essentiel et fonctionnel
- Rapport qualité-prix excellent
- Wi-Fi et Bluetooth inclus

- Wesentlich und funktionell
- Ausgezeichnetes Preis-Leistungs-Verhältnis
- Integrierte WLAN und Bluetooth

			
Classificazione 5 stelle (D.M.186)	Wi-Fi Bluetooth*	Comfort mode**	Up. back. lat. (v. 7)
			
Back. lateral (v. 7)	Up (v. 7 Up)	71/197	12

* **Gestione tramite Wi-Fi e Bluetooth integrati.**
Control through integrated Wi-Fi and Bluetooth.
Gestion via Wi-Fi et Bluetooth intégrés.
Verwaltung über WLAN und integriertes Bluetooth.

** **Disattiva i ventilatori per garantire la massima silenziosità.**
Deactivates stove fans, to guarantee maximum silence.
Désactivez les ventilateurs afin de garantir le maximum de silence.
Deaktivierung der Gebläse, um maximale Ruhe zu gewährleisten.

6,9 kW





Grace 7



Grace 7 Up



Grace 7 Up-Twin

Scopri le
caratteristiche
del prodotto
e il tuo risparmio
con il conto
termico

Grace 7

7/7 Up/7 Up-Twin



Upgrade









- Nuovo top con uscita fumi superiore anche con versione coassiale
- Soli 27,5 cm di profondità
- Possibilità di installazione a parete o sospesa



- New top with coaxial upper smoke outlet
- Only 27.5 cm deep
- Possibility of wall or suspended installation

- Nouveau couvercle avec sortie coaxiale supérieure des fumées
- Seulement 27,5 cm de profondeur
- Possibilité d'installation au mur ou suspendue

- Neue Topplatte mit koaxialem oberem Rauchauslass
- Nur 27,5 cm Tiefe
- Möglichkeit der Installation an der Wand oder hängend

 Classificazione 5 stelle (D.M.186)	 Wi-Fi Bluetooth*	 Comfort mode**	 Up. back. lat. (v. 7)
 Back. lateral (v. 7)	 Up (v. 7 Up)	 71/197	 32

*** Gestione tramite Wi-Fi e Bluetooth integrati.**
Control through integrated Wi-Fi and Bluetooth.
Gestion via Wi-Fi et Bluetooth intégrés.
Verwaltung über WLAN und integriertes Bluetooth.

**** Disattiva i ventilatori per garantire la massima silenziosità.**
Deactivates stove fans, to guarantee maximum silence.
Désactivez les ventilateurs afin de garantir le maximum de silence.
Deaktivierung der Gebläse, um maximale Ruhe zu gewährleisten.

6,9 kW





Baggy 7



Baggy 7 Up



Baggy 7 Up-Twin

Scopri le
caratteristiche
del prodotto
e il tuo risparmio
con il conto
termico

Baggy 7

7/7 Up/7 Up-Twin



- Grande serbatoio da 32 kg
- Da 3 a 6 giorni di autonomia con una sola ricarica
- Solo 28 cm di spessore

- Large 32 kg hopper
- Runs 3 to 6 days with a single refill
- Only 28 centimetres thick

- Grand réservoir de 32kg
- 3 à 6 jours d'autonomie avec une seule recharge
- Épaisseur réduite de 28 cm

- Großer 32-kg-Behälter
- 3 bis 6 Tage mit einer einzigen Nachfüllung
- Geringe Tiefe von nur 28 cm

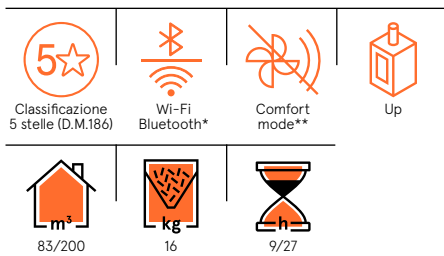

*** Gestione tramite Wi-Fi e Bluetooth integrati.**
Control through integrated Wi-Fi and Bluetooth.
Gestion via Wi-Fi et Bluetooth intégrés.
Verwaltung über WLAN und integriertes Bluetooth.

**** Disattiva i ventilatori per garantire la massima silenziosità.**
Deactivates stove fans, to guarantee maximum silence.
Désactivez les ventilateurs afin de garantir le maximum de silence.
Deaktivierung der Gebläse, um maximale Ruhe zu gewährleisten.

7 kW





Scopri le
caratteristiche
del prodotto
e il tuo risparmio
con il conto
termico

Bold 7

Up-Twin

- Scarico coassiale superiore integrato
- Camera di combustione con schiena in ghisa
- Ventilazione superiore e frontale



- Integrated upper coaxial exhaust
- Combustion chamber with cast iron back
- Top and front ventilation
- Évacuation coaxiale supérieure intégrée
- Chambre de combustion avec dos en fonte
- Ventilation supérieure et frontale
- Integrierter oberer koaxialer Auslass
- Brennkammer mit Gusseisenrückwand
- Ventilation von oben und von vorne





Classificazione
5 stelle (D.M.186)



Wi-Fi
Bluetooth*



Comfort
mode**



Back



83/200



15



9/25

*** Gestione tramite Wi-Fi e Bluetooth integrati.**
Control through integrated Wi-Fi and Bluetooth.
Gestion via Wi-Fi et Bluetooth intégrés.
Verwaltung über WLAN und integriertes Bluetooth.

**** Disattiva i ventilatori per garantire la massima silenziosità.**
Deactivates stove fans, to guarantee maximum silence.
Désactivez les ventilateurs afin de garantir le maximum de silence.
Deaktivierung der Gebläse, um maximale Ruhe zu gewährleisten.

7 kW





Scopri le
caratteristiche
del prodotto
e il tuo risparmio
con il conto
termico

- Classic design
- Top, burning pot and back of combustion chamber in cast iron
- Wide range of steel and high-quality ceramic claddings
- Design classique
- Couvercle, brasero et dos de la chambre de combustion en fonte
- Large gamme d'habillages en acier et céramique raffinée
- Klassisches Design
- Topplatte, Brennschale und Rückwand der Brennkammer aus Gusseisen
- Große Palette an Verkleidungen aus Stahl oder Keramik

Perla 7



- Design classico
- Top, braciere e schiena della camera di combustione in ghisa
- Ampia gamma di rivestimenti, sia in acciaio che in ceramica pregiata



Classificazione
5 stelle (D.M.186)



Wi-Fi
Bluetooth*



Comfort
mode**



Back

* **Gestione tramite Wi-Fi e Bluetooth integrati.**
Control through integrated Wi-Fi and Bluetooth.
Gestion via Wi-Fi et Bluetooth intégrés.
Verwaltung über WLAN und integriertes Bluetooth.

** **Disattiva i ventilatori per garantire la massima silenziosità.**
Deactivates stove fans, to guarantee maximum silence.
Désactivez les ventilateurs afin de garantir le maximum de silence.
Deaktivierung der Gebläse, um maximale Ruhe zu gewährleisten.

7 kW



83/200 m³



15 kg



9/25 h





Scopri le
caratteristiche
del prodotto
e il tuo risparmio
con il conto
termico

Sweet 7











- Look pulito e moderno
- Semplicità d'uso
- Wi-Fi e Bluetooth incluso

- Clean and modern look
- Easy to use
- Wi-Fi and Bluetooth included

- Look soigné et modern
- Simplicité d'utilisation
- Wi-Fi et Bluetooth inclus

- Sauberes und modernes Aussehen
- Einfache Nutzung
- Integrierte WLAN und Bluetooth



			
Classificazione 5 stelle (D.M.186)	Go Fast*	Wi-Fi Bluetooth	Comfort mode**
			
Up	92/190	8	5/11

*** Candeletta di tipo ceramico che garantisce un'accensione più rapida del pellet.**
Glow plug that guarantees faster pellet ignition.
Bougie de préchauffage de type céramique qui garantit un allumage plus rapide du pellet.
Keramischen Zündkerze stand, die eine schnellere Zündung der Pellets.

**** Disattiva i ventilatori per garantire la massima silenziosità.**
Deactivates stove fans, to guarantee maximum silence.
Désactivez les ventilateurs afin de garantir le maximum de silence.
Deaktivierung der Gebläse, um maximale Ruhe zu gewährleisten.

7 kW





Scopri le
caratteristiche
del prodotto
e il tuo risparmio
con il conto
termico

- Wide vision of the flame
- The dimensions fit perfectly into existing fireplaces
- Pellet loading via extraction, chute or drawer optional
- Front ventilation
- Grande vision de la flamme
- Les dimensions s'adaptent parfaitement aux cheminées existantes
- Chargement des granulés par extraction, trappe ou tiroir en option
- Ventilation frontale
- Schönheit der Sicht auf die Flamme
- Die Abmessungen passen perfekt zu bestehenden Schornsteinen
- Pellet wird durch Extraktion, Ladeklappe oder Schubfach geladen
- Frontale Lüftung

Ponente 7

- **Ampia visione della fiamma**
- **Perfetta adattabilità ai camini esistenti**
- **Caricamento pellet tramite estrazione, botola o cassetto opzionali**
- **Ventilazione frontale**



opt



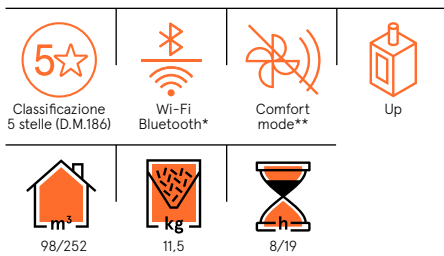

* **Gestione tramite Wi-Fi e Bluetooth integrati.**
Control through integrated Wi-Fi and Bluetooth.
Gestion via Wi-Fi et Bluetooth intégrés.
Verwaltung über WLAN und integriertes Bluetooth.

** **Disattiva i ventilatori per garantire la massima silenziosità.**
Deactivates stove fans, to guarantee maximum silence.
Désactivez les ventilateurs afin de garantir le maximum de silence.
Deaktivierung der Gebläse, um maximale Ruhe zu gewährleisten.

9 kW





Box Up-Twin



Up-Twin

Scopri le
caratteristiche
del prodotto
e il tuo risparmio
con il conto
termico

Quasimodo 9









Box Up-Twin/Up-Twin



- Powerful and airtight stove
- A simple shape that decorates
- Wide glass door and cast-iron firebox
- Poêle puissant et étanche
- Une forme essentielle qui décore
- Grande porte vitrée et foyer en fonte
- Leistungsstarker Ofen mit luftdichter Brennkammer
- Eine wesentliche Form, die einrichtet und dekoriert
- Große Glastür und gusseiserner Brennkammer

-
- **Stufa potente ed ermetica**
 - **Una forma essenziale che arreda**
 - **Ampia porta in vetro e focolare in ghisa**
-



			
Classificazione 5 stelle (D.M.186)	Wi-Fi Bluetooth*	Comfort mode**	Up
			
Ducting kit***	98/252	15 kg	8/19 h

*** Gestione tramite Wi-Fi e Bluetooth integrati.**
Control through integrated Wi-Fi and Bluetooth.
Gestion via Wi-Fi et Bluetooth intégrés.
Verwaltung über WLAN und integriertes Bluetooth.

afin de garantir le maximum de silence.
Deaktivierung der Gebläse, um maximale Ruhe zu gewährleisten.

**** Disattiva i ventilatori per garantire la massima silenziosità.**
Deactivates stove fans, to guarantee maximum silence.
Désactivez les ventilateurs

***** Kit canalizzazione (opzionale).**
Ducting kit (optional).
Kit conduits de canalisation (opt.).
Kit für Kanalisierung (optional).

9 kW





Scopri le
caratteristiche
del prodotto
e il tuo risparmio
con il conto
termico

Zefiro 9











- **Inserto che offre una bella visione della fiamma**
- **Perfetto per camini esistenti**
- **Possibilità di canalizzazione con Kit opzionale**

- Insert that offers a beautiful view of the flame
- Fits perfectly to existing fireplaces
- Ducting available with optional kit

- Insert qui offre une belle vue sur la flamme
- Parfait pour les cheminées existantes
- Solutions de canalisation avec kit en option

- Einsatz mit guter Sicht auf die Flamme
- Perfekt für bereit bestehende Kamine
- Möglichkeit der Luftkanalisierung durch optionales Zubehörset

			
Classificazione 5 stelle (D.M.186)	Wi-Fi Bluetooth*	Comfort mode**	Back (v.9)
			
Up (v.9 Up-Twin)	Ducting kit***	98/252	15

*** Gestione tramite Wi-Fi e Bluetooth integrati.**
Control through integrated Wi-Fi and Bluetooth.
Gestion via Wi-Fi et Bluetooth intégrés.
Verwaltung über WLAN und integriertes Bluetooth.

afin de garantir le maximum de silence.
Deaktivierung der Gebläse, um maximale Ruhe zu gewährleisten.

**** Disattiva i ventilatori per garantire la massima silenziosità.**
Deactivates stove fans, to guarantee maximum silence.
Désactivez les ventilateurs

***** Kit canalizzazione (opzionale).**
Ducting kit (optional).
Kit conduits de canalisation (opt.).
Kit für Kanalisierung (optional).

9 kW





Frame 9 Ps



Frame 9 Up-Twin

Scopri le
caratteristiche
del prodotto
e il tuo risparmio
con il conto
termico

Frame 9

Ps/Up-Twin

- Raffinata e metropolitana
- Ampio vetro per una panoramica visione della fiamma
- Possibilità di canalizzazione con Kit opzionale



- Sophisticated and metropolitan
- Wide glass for a panoramic view of the flame
- Ducting available with optional kit

- Élégant et métropolitain
- Large vitre pour une vue panoramique de la flamme
- Solutions de canalisation avec kit en option

- Raffiniert und zeitgenössisch
- Großes Glas für einen Panoramablick auf die Flamme
- Möglichkeit der Luftkanalisierung durch optionales Zubehörset

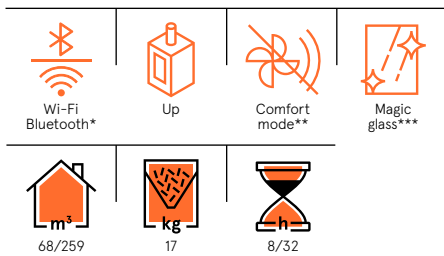

* **Gestione tramite Wi-Fi e Bluetooth integrati.**
Control through integrated Wi-Fi and Bluetooth.
Gestion via Wi-Fi et Bluetooth intégrés.
Verwaltung über WLAN und integriertes Bluetooth.

afin de garantir le maximum de silence.
Deaktivierung der Gebläse, um maximale Ruhe zu gewährleisten.

** **Disattiva i ventilatori per garantire la massima silenziosità.**
Deactivates stove fans, to guarantee maximum silence.
Désactivez les ventilateurs

*** **Vetro oscurato Magic Glass a stufa spenta.**
Magic Glass tinted glass when the stove is off.
Vitre obscurcie Magic Glass lorsque le poêle est éteint. / Getönte Magic Glas Glasscheibe bei ausgeschaltetem Ofen.

9,1 kW





Scopri le
caratteristiche
del prodotto
e il tuo risparmio
con il conto
termico

Shell 9 Up-Twin



- Linee morbide e materiali high tech
- Vetro oscurato Magic Glass a stufa spenta
- Scarico fumi superiore

- Soft lines and high-tech materials
- Magic Glass tinted glass when the stove is off
- Upper exhaust

- Lignes souples et matériaux high tech
- Vitre obscurcie Magic Glass lorsque le poêle est éteint
- Sortie des fumées supérieure

- Weiche Linien und High-Tech-Materialien
- Getönte Magic Glas Glasscheibe bei ausgeschaltetem Ofen
- Rauchgasabzug oben

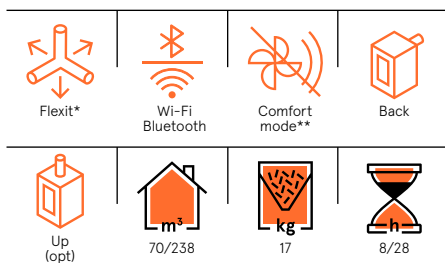

*** Flessibilità di installazione (uscita dei fumi e aria calda canalizzabile)**
Flexibility in terms of installation (smoke outlet and ductable hot air)
Flexibilité en termes d'installation (sorties des fumées et air chaud canalisable)/Flexibilität bei der Installation (Rauchgasabzugs und kanalisierbaren von Warmluft)

**** Disattiva i ventilatori per garantire la massima silenziosità.**
Deactivates stove fans, to guarantee maximum silence.
Désactivez les ventilateurs afin de garantir le maximum de silence.
Deaktivierung der Gebläse, um maximale Ruhe zu gewährleisten.

8,5 kW





Cristal 9



Cristal Plus 9

Scopri le **caratteristiche del prodotto** e il tuo risparmio con il **conto termico**

Cristal 9 Cristal Plus 9











- Canalizzabile
- Porta in ghisa diamantata e bombata
- Top piatto
- Flexit
- 4 stelle AriaPulita™ ma con emissioni polveri da 5 stelle

- Ductable
- Bevelled and diamond-shaped cast iron door
- Combustion chamber with cast iron back
- Flexit

- Canalisable
- Porte en fonte à section biseautée et convexe
- Chambre de combustion avec dos en fonte
- Flexit

- Kanalisierbar
- Mit Diamantschliff bearbeitete und gewölbte Tür aus Gusseisen
- Brennkammer mit Gusseisenrückwand
- Flexit

 Classificazione 5 stelle (D.M.186)	 Airtech Braicere autopulente*	 Kit UPS Ready**	 Flexit
 Go Fast	 Wi-Fi Bluetooth	 90/238	 kg 20

*** Sistema di pulizia automatica del braciere.**
Innovative automatic brazier cleaning system. Système innovant de nettoyage automatique du brâsero. Innovative automatische Brennschale Reinigungssystem.

**** Accessorio per predisporre la stufa al collegamento di una batteria di backup esterna.**
Accessory to prepare the stove to connect an external backup battery. Accessoire pour préparer le poêle au raccordement d'une batterie de secours externe. Zubehör zur Vorbereitung des Ofens für den Anschluss einer externen Pufferbatterie.

8,5 kW





Airtech



Air

Scopri le
caratteristiche
del prodotto
e il tuo risparmio
con il conto
termico

Cristal 9

Airtech/Air

Upgrade









- Porta in ghisa diamantata e bombata
- Braciere autopulente nella versione Airtech
- Camera di combustione con schiena in ghisa
- UPS Ready, comfort anche durante blackout
- Classificazione 5 stelle (D.M.186)



- Bevelled and diamond-shaped cast iron door
- Self-cleaning brazier in the Airtech version
- Combustion chamber with cast iron back
- UPS Ready: comfort even during blackouts

- Porte en fonte à section biseautée et convexe
- Brasero autonettoyant en version Airtech
- Chambre de combustion avec dos en fonte
- UPS Ready, le confort même pendant les coupures de courant

- Mit Diamantschliff bearbeitete und gewölbte Tür aus Gusseisen
- Selbstreinigende Brennschale in der Airtech-Version
- Brennkammer mit Gusseisenrückwand
- UPS Ready

 Classificazione 5 stelle (D.M.186)	 Airtech Braciere autopulente*	 Kit UPS Ready**	 Comfort mode
 Wi-Fi Bluetooth	 90/238	 20	 11/29

*** Sistema di pulizia automatica del braciere.**
Innovative automatic
brazier cleaning system.
Système innovant de
nettoyage automatique
du brasero.
Innovative automatische
Brennschale
Reinigungssystem.

**** Accessorio per predisporre la stufa al collegamento di una batteria di backup esterna.**
Accessory to prepare
the stove to connect an
external backup battery.
Accessoire pour préparer
le poêle au raccordement
d'une batterie de secours
externe.
Zubehör zur Vorbereitung
des Ofens für den
Anschluss einer externen
Pufferbatterie.

8,5 kW





Airtech Up-Twin



Airtech Ps

Scopri le
caratteristiche
del prodotto
e il tuo risparmio
con il conto
termico

- Rivestimento materico in ghisa
- Ampia visione della fiamma
- Braciere autopulente
- Disponibile con uscita fumi superiore e posteriore
- Classificazione 5 stelle (D.M.186)

Spin Plus 9

Airtech Up-Twin/Airtech Ps



Upgrade

- Textured cast-iron cladding
- Wide view of the fire
- Self-cleaning brazier
- Available with upper and back exhaust
- Matériau de revêtement en fonte
- Vue élargie de la flamme
- Brasero autonettoyant
- Disponible avec sortie fumées supérieure et postérieure
- Strukturierte gusseiserne Verkleidung
- Vergrößerte Sicht auf die Flamme
- Selbstreinigende Brennschale
- Abgasstutzen Hinten und Oben erhältlich



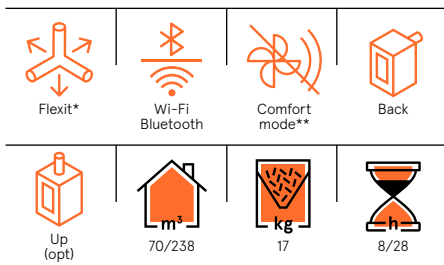

*** Flessibilità di installazione (uscita dei fumi e aria calda canalizzabile)**
Flexibility in terms of installation (smoke outlet and ductable hot air)
Flexibilité en termes d'installation (sorties des fumées et air chaud canalisable)/Flexibilität bei der Installation (Rauchgasabzugs und kanalisierbaren von Warmluft)

****Disattiva i ventilatori per garantire la massima silenziosità.**
Deactivates stove fans, to guarantee maximum silence.
Désactivez les ventilateurs afin de garantir le maximum de silence.
Deaktivierung der Gebläse, um maximale Ruhe zu gewährleisten.

8,5 kW





Scopri le
caratteristiche
del prodotto
e il tuo risparmio
con il conto
termico

Icon Plus 9

- Design moderno e linee semplici
- Canalizzabile
- Originale top in ghisa
- Elegante porta in vetro
- 4 stelle D.M.186 ma con emissioni polveri da 5 stelle
- Flexit



- Modern design and neat lines
- Ductable
- Unique cast iron top
- Elegant glass door
- Flexit

- Design moderne et lignes simples
- Canalisable
- Couverture original en fonte
- Élégante porte vitrée
- Flexit

- Modernes Design und einfache Linien
- Kanalisierbar
- Original-Topplatte aus Gusseisen
- Elegante Glastür
- Flexit

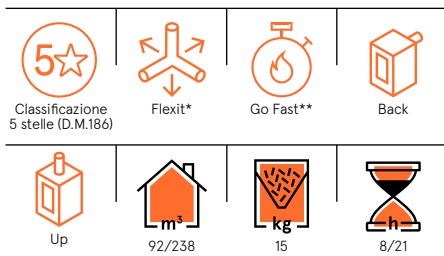

*** Flessibilità di installazione (uscita dei fumi e aria calda canalizzabile)**
Flexibility in terms of installation (smoke outlet and ductable hot air)
Flexibilité en termes d'installation (sorties des fumées et air chaud canalisable)/Flexibilität bei der Installation (Rauchgasabzugs und kanalisierbaren von Warmluft)

**** Candeletta di tipo ceramico che garantisce un'accensione più rapida del pellet.**
Glow plug that guarantees faster pellet ignition.
Bougie de préchauffage de type céramique qui garantit un allumage plus rapide du pellet.
Keramischen Zünderkerze stand, die eine schnellere Zündung der Pellets.

8,5 kW





Flexit



Up-Twin

Scopri le
caratteristiche
del prodotto
e il tuo risparmio
con il conto
termico

- Moderna, compatta e salvaspazio
- Scarico fumi: posteriore e superiore, coassiale
- Dotata di griglia frontale inferiore per l'uscita dell'aria
- Flexit

Luce Plus 9

Flexit/Up-Twin



- Modern, slim and space saving
- Upper exhaust: top, rear or coaxial
- Lower front grill
- Flexit

- Moderne, étroit et peu encombrant
- Sortie des fumées supérieure, postérieure ou coaxial
- Avec une grille frontale
- Flexit

- Modern und Platzsparend
- Rauchabgas oben, hinten oder koaxial
- Warme Luft kommt auch vom unteren Gitter
- Flexit

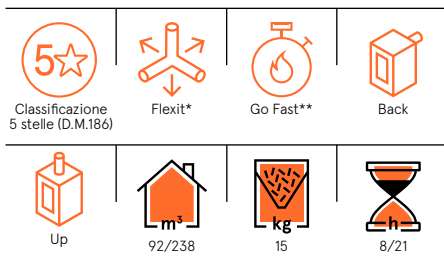

*** Flessibilità di installazione (uscita dei fumi e aria calda canalizzabile)**
Flexibility in terms of installation (smoke outlet and ductable hot air)
Flexibilité en termes d'installation (sorties des fumées et air chaud canalisable)/Flexibilität bei der Installation (Rauchgasabzugs und kanalisierbaren von Warmluft)

**** Candeletta di tipo ceramico che garantisce un'accensione più rapida del pellet.**
Glow plug that guarantees faster pellet ignition.
Bougie de préchauffage de type céramique qui garantit un allumage plus rapide du pellet.
Keramischen Zündkerze stand, die eine schnellere Zündung der Pellets.

8,5 kW





Flexit



Up-Twin

Scopri le
caratteristiche
del prodotto
e il tuo risparmio
con il conto
termico

Elle Plus 9

Flexit/Up-Twin

- Contemporanea ed elegante, con cornice in acciaio e vetro
- Disponibile con frontale in Gres Porcellanato: Pietra Nero Greco ed Ossido Bruno
- Flexit



opt



1-2-3











7



- Contemporary and elegant, with a steel and glass frame
- Essential and material, enhanced by the front panel made of stone
- Flexit

- Contemporain et élégant, avec un cadre en acier
- Essentiel et matérieue, rehaussé par l'habillage en pierre
- Flexit

- Zeitgemäß und elegant, mit einem Stahlrahmen
- Wesentlich und materisch, aufgewertet durch einen stimmungsvollen Seitenteil aus Stein.
- Flexit

 Wi-Fi Bluetooth*	 Comfort mode**	 Up, back, lat.	 Back, lateral (FRANCE)
 Ducting***	 86/285	 15	 7/23

* **Gestione tramite Wi-Fi e Bluetooth integrati.**
Control through integrated Wi-Fi and Bluetooth.
Gestion via Wi-Fi et Bluetooth intégrés.
Verwaltung über WLAN und integriertes Bluetooth.

afin de garantir le maximum de silence.
Deaktivierung der Gebläse, um maximale Ruhe zu gewährleisten.

** **Disattiva i ventilatori per garantire la massima silenziosità.**
Deactivates stove fans, to guarantee maximum silence.
Désactivez les ventilateurs

*** **Canalizzazione 1 motore indipendente.**
Duction with 1 independent motor.
Conduits d'aération avec 1 moteur indépendant.
Kanalisierung mit 1 unabhängigen Luftgebläse.

10 kW





Scopri le
caratteristiche
del prodotto
e il tuo risparmio
con il **conto**
termico

- Minimalist design
- Only 29 cm deep, for confined spaces
- Perfect for small walls, corridors or to be suspended









- Design minimaliste
- Seulement 29 cm de profondeur, pour les petits espaces
- Parfait pour des murs de petite largeur, des couloirs ou l'installation suspendue

- Minimalistisches Design
- Nur 29 cm Tiefe, für enge Platzverhältnisse
- Perfekt für kleine Wände, Flure oder zum Aufhängen

Wall Plus 10



-
- **Design minimale**
 - **Soli 29 cm di profondità, per gli spazi ristretti**
 - **Perfetta per piccole pareti, corridoi o sospesa**
-

 Wi-Fi Bluetooth*	 Comfort mode**	 Up, back, lat.	 Back, lateral (FRANCE)
 Up (OPT FRANCE)	 Ducting***	 86/285	 8/27

* **Gestione tramite Wi-Fi e Bluetooth integrati.**
Control through integrated Wi-Fi and Bluetooth.
Gestion via Wi-Fi et Bluetooth intégrés.
Verwaltung über WLAN und integriertes Bluetooth.

afin de garantir le maximum de silence.
Deaktivierung der Gebläse, um maximale Ruhe zu gewährleisten.

** **Disattiva i ventilatori per garantire la massima silenziosità.**
Deactivates stove fans, to guarantee maximum silence.
Désactivez les ventilateurs

*** **Canalizzazione 1 motore indipendente.**
Duction with 1 independent motor.
Conduits d'aération avec 1 moteur indépendant.
Kanalisierung mit 1 unabhängigen Luftgebläse.

10 kW





Scopri le
caratteristiche
del prodotto
e il tuo risparmio
con il **conto**
termico

- Elegant shape
- Only 27 cm deep, for confined spaces
- Upper, back and lateral exhaust









- Forme élégante
- Seulement 27 cm de profondeur, pour les petits espaces
- Sortie des fumées supérieure, postérieure ou latérale

- Elegante Form
- Nur 27 cm Tiefe, für enge Platzverhältnisse
- Rauchgasabzug oben, hinten oder seitlich

Tile Plus 10



-
- Forma elegante
 - Soli 27 cm di profondità, per gli spazi ristretti
 - Scarico fumi superiore, posteriore o laterale
-

			
Classificazione 5 stelle (D.M.186)	Flexit*	Go Fast**	Wi-Fi Bluetooth
			
Back	Up (opt)	84/294	10/36

*** Flessibilità di installazione (uscita dei fumi e aria calda canalizzabile)**
 Flexibility in terms of installation (smoke outlet and ductable hot air)
 Flexibilité en termes d'installation (sorties des fumées et air chaud canalisable)/Flexibilität bei der Installation (Rauchgasabzug und kanalisierbaren von Warmluft)

**** Candeletta di tipo ceramico che garantisce un'accensione più rapida del pellet.**
 Glow plug that guarantees faster pellet ignition.
 Bougie de préchauffage de type céramique qui garantit un allumage plus rapide du pellet.
 Keramischen Zündkerze stand, die eine schnellere Zündung der Pellets.

10,5 kW





Prince 11



Prince Plus 11

Scopri le
caratteristiche
del prodotto
e il tuo risparmio
con il conto
termico

Prince 11 Prince Plus 11











- Canalizzabile
- Forma squadrata
impreziosita da un'elegante
cornice bicolore
- 5 stelle D.M.186
- Flexit



- Ductable
- Squared lines enriched
by an elegant bicolour frame
- Flexit

- Canalisable
- Forme carrée enrichie
par un élégant cadre
bicolore
- Flexit

- Kanalisierbar
- Quadratische Form
mit elegantem
zweifarbigen Rahmen
- Flexit

			
Classificazione 5 stelle (D.M.186)	Flexit*	Go Fast**	Wi-Fi Bluetooth
			
Back	Up (opt)	84/294	10/36

*** Flessibilità di installazione (uscita dei fumi e aria calda canalizzabile)**
Flexibility in terms of installation (smoke outlet and ductable hot air)
Flexibilité en termes d'installation (sorties des fumées et air chaud canalisable)/Flexibilität bei der Installation (Rauchgasabzugs und kanalisierbaren von Warmluft)

**** Candeletta di tipo ceramico che garantisce un'accensione più rapida del pellet.**
Glow plug that guarantees faster pellet ignition.
Bougie de préchauffage de type céramique qui garantit un allumage plus rapide du pellet.
Keramischen Zündkerze stand, die eine schnellere Zündung der Pellets.

10,5 kW





Kobe 11



Kobe Plus 11

Scopri le **caratteristiche del prodotto** e il tuo risparmio con il **conto termico**

Kobe 11 Kobe Plus 11

- Canalizzabile
- Ampia scelta di colori per la cornice frontale
- Ampia visione della fiamma
- Top dal design innovativo per una canalizzazione versatile
- 5 stelle D.M.186
- Flexit



- Ductable
- Wide choice of colours for the front frame
- Wide view of the flame
- Innovatively designed top for versatile ducting
- Flexit

- Canalisable
- Large choix de couleurs pour le cadre frontal
- Grande vision de la flamme
- Couvercle au design innovant pour une canalisation polyvalente
- Flexit

- Kanalisierbar
- Große Auswahl an Farben für den Frontrahmen
- Gute Sicht auf die Flamme
- Topplatte mit innovativem Design für eine vielseitige Kanalisierung
- Flexit

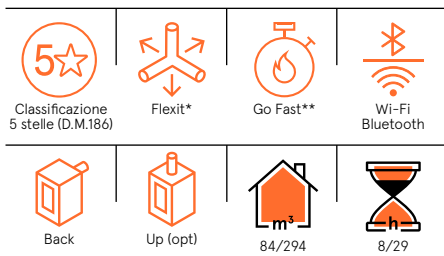

*** Flessibilità di installazione (uscita dei fumi e aria calda canalizzabile)**
Flexibility in terms of installation (smoke outlet and ductable hot air)
Flexibilité en termes d'installation (sorties des fumées et air chaud canalisable)/Flexibilität bei der Installation (Rauchgasabzugs und kanalisierbaren von Warmluft)

**** Candeletta di tipo ceramico che garantisce un'accensione più rapida del pellet.**
Glow plug that guarantees faster pellet ignition.
Bougie de préchauffage de type céramique qui garantit un allumage plus rapide du pellet.
Keramischen Zündkerze stand, die eine schnellere Zündung der Pellets.

10,5 kW





Fenice 11



Fenice Plus 11

Scopri le **caratteristiche del prodotto** e il tuo risparmio con il **conto termico**

Fenice 11 Fenice Plus 11



- **Canalizzabile**
- **L'arte che arreda e riscalda, perfetto complemento d'arredo dalla grande personalità**
- **Struttura dalla forma curva con top anello dalle finiture preziose**
- **5 stelle D.M.186**
- **Flexit**

- Ductable
- Art that furnishes and heats, a perfect interior design item with a great personality
- Structure with curved shape and ring top with precious finishes
- Flexit

- Canalisable
- L'art qui meuble et qui chauffe, le mobilier de complément idéal, affichant une grande personnalité
- Structure à la forme ronde avec un couvercle en forme d'anneau aux finitions précieuses
- Flexit

- Kanalisierbar
- Kunst, die einrichtet und wärmt, der perfekte Einrichtungsgegenstand mit Charakter
- Abgerundete Struktur mit edler Ring-Topplatte
- Flexit

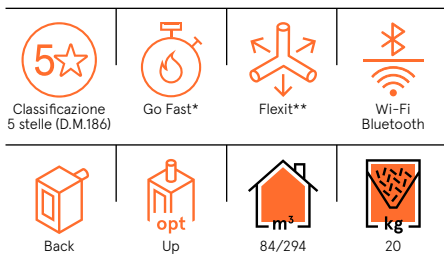

*** Candeletta di tipo ceramico che garantisce un'accensione più rapida del pellet.**
Glow plug that guarantees faster pellet ignition.
Bougie de préchauffage de type céramique qui garantit un allumage plus rapide du pellet.
Keramischen Zündkerze stand, die eine schnellere Zündung der Pellets

**** Flessibilità di installazione (uscita dei fumi e aria calda canalizzabile).**
Flexibility in terms of installation (smoke outlet and ductable hot air).
Flexibilité en termes d'installation (sorties des fumées et air chaud canalisable).
Flexibilität bei der Installation (Rauchgasabzugs und kanalisierbaren von Warmluft)

10,5 kW





Scopri le
caratteristiche
del prodotto
e il tuo risparmio
con il conto
termico









Eclipse Plus 11

- **Morbide forme arrotondate**
- **Vetro curvo**
- **Top in ghisa**
- **Flexit**
- **5 stelle D.M.186**



- Soft rounded shapes
- Cast iron top
- Curved glass
- Flexit
- Formes arrondies et douces
- Couvercle en fonte
- Verre courbé
- Flexit
- Weiche, abgerundete Formen
- Topplatte aus Gusseisen
- Gebogenes Glas
- Flexit



			
Classificazione 5 stelle (D.M.186)	Wi-Fi Bluetooth	Flexit*	Comfort mode
			
Back	Up	Duction**	105/342 (v.12) 105/390 (v.14)

*** Flessibilità di installazione (uscita dei fumi e aria calda canalizzabile)**
Flexibility in terms of installation (smoke outlet and ductable hot air)
Flexibilité en termes d'installation (sorties des fumées et air chaud canalisable)/Flexibilität bei der Installation (Rauchgasabzugs und kanalisierbaren von Warmluft)

**** Canalizzazione 2 motori indipendenti**
Duction with 2 independ. motors
Conduits d'aération avec 2 moteurs indépendants
Kanalisierung mit 2 unabhängigen Luftgebläsen

12/
13,7 kW





Atena Plus 12



Atena Plus 14

Scopri le **caratteristiche del prodotto** e il tuo risparmio con il **conto termico**

Atena Plus 12/14











- **Doppia canalizzazione posteriore o superiore con gestione indipendente**
- **Wi-Fi e bluetooth integrati per il controllo da remoto**
- **Uscita fumi posteriore, superiore in opzione**

- Dual rear or top ducting managed independently
- Built-in Wi-Fi and Bluetooth for remote control
- Back exhaust, upper as option

- Double canalisation postérieure ou supérieure avec gestion indépendante
- Wi-Fi et Bluetooth intégrés pour le contrôle à distance
- Sortie de fumée postérieure, supérieure en option

- Doppelte Luftkanalisierung mit unabhängiger Steuerung hinten oder oben
- Mit integriertem WLAN und Bluetooth zur Fernsteuerung
- Rauchabzug hinten, oben als Option

 Classificazione 5 stelle (D.M.186)	 Wi-Fi Bluetooth*	 Comfort mode**	 Up (v. Up)
 Back (v. Ps)	 Duction***	 105/342 (12) 105/390 (14)	 23

* **Gestione tramite Wi-Fi e Bluetooth integrati.**
Control through integrated Wi-Fi and Bluetooth.
Gestion via Wi-Fi et Bluetooth intégrés.
Verwaltung über WLAN und integriertes Bluetooth.

afin de garantir le maximum de silence.
Deaktivierung der Gebläse, um maximale Ruhe zu gewährleisten.

** **Disattiva i ventilatori per garantire la massima silenziosità.**
Deactivates stove fans, to guarantee maximum silence.
Désactivez les ventilateurs

*** **Canalizzazione 2 motori indipendenti**
Duction with 2 independent motors.
Conduits d'aération avec 2 moteurs indépendants.
Kanalisierung mit 2 unabhängigen Luftgebläsen.

12/
13,7 kW





Mithos Plus 12 Ps



Mithos Plus 14 Ps



Mithos Plus 12
Up-Twin



Mithos Plus 14
Up-Twin

Scopri le
**caratteristiche
del prodotto**
e il tuo risparmio
con il **conto
termico**

Mithos Plus 12/14

Ps/Up-Twin











- **Design minimal e molteplici soluzioni installative**
- **Griglie di ventilazione frontali inferiori e migliore distribuzione dell'aria**
- **Wi-Fi integrato**



- Minimal design and multiple installation solutions
- Lower front ventilation grilles and improved air distribution
- Built-in Wi-Fi

- Design minimaliste et multiples solutions d'installation
- Grilles de ventilation frontales dans le bas et meilleure distribution de l'air
- Wi-Fi intégré

- Minimalistisches Design und viele Installationsmöglichkeiten
- Belüftungsgitter vorn unten und bessere Verteilung der Luft
- Integriertes WLAN

 Classificazione 5 stelle (D.M.186)	 Idrotech Braciere autopulente*	 Go Fast**	 Wi-Fi Bluetooth
 Back	 Collegam. imp. riscaldamento***	 123/496 (v.18) 123/678 (v.24)	 kg 24

*** Sistema di pulizia automatica del braciere.**
Innovative automatic brazier cleaning system.
Système innovant de nettoyage automatique du brasero.
Innovative automatische Brennschalenreinigungssystem.

faster pellet ignition.
Bougie de préchauffage de type céramique qui garantit un allumage plus rapide du pellet.
Keramischen Zündkerze stand, die eine schnellere Zündung der Pellets.

**** Candeletta di tipo ceramico che garantisce un'accensione più rapida del pellet.**
Glow plug that guarantees

***** Colleg. all'impianto di riscaldamento.**
Connection to the heating system. / Raccordement avec système de chauffage. / Anschluss zu Heizungssystem.

17,7/
24,2 kW





River idro 18



River idro 24

Scopri le
caratteristiche
del prodotto
e il tuo risparmio
con il conto
termico









River Idro 18/24

Idrotech

- **Versione con braciere autopulente**
- **Stufa dalle alte prestazioni per il riscaldamento centralizzato della casa**
- **5 stelle D.M.186**
- **Candeletta ceramica**



- | | | |
|--|---|---|
| <ul style="list-style-type: none"> ● Version with self-cleaning brazier ● High-performance stove for centralised heating of the home ● Ceramic plug | <ul style="list-style-type: none"> ● Version avec brasero autonettoyant ● Poêle aux performances élevées pour le chauffage centralisé des habitations ● Préchauffage de type céramique | <ul style="list-style-type: none"> ● Version mit selbstreinigender Brennschale ● Leistungsstarker Ofen für die Zentralheizung des Hauses ● Keramischen Zündkerze |
|--|---|---|

			
Classificazione 5 stelle (D.M.186)	Go Fast*	Wi-Fi Bluetooth**	Back
			
Collegam. imp. riscaldamento***	137/451 (v.16) 137/627 (v.23)	6/22 (v.16) 4/22 (v.23)	22

*** Candeletta di tipo ceramico che garantisce un'accensione più rapida del pellet.**
Glow plug that guarantees faster pellet ignition.
Bougie de préchauffage de type céramique qui garantit un allumage plus rapide du pellet.
Keramischen Zündkerze stand, die eine schnellere Zündung der Pellets.

**** Gestione tramite Wi-Fi e Bluetooth integrati.**
Control through integrated Wi-Fi and Bluetooth.
Gestion via Wi-Fi et Bluetooth intégrés.
Verwaltung über WLAN und integriertes Bluetooth.

***** Colleg. all'impianto di riscaldamento.**
Connection to the heating system. / Raccordement avec système de chauffage. / Anschluss zu Heizungssystem.

16,1/
22,4 kW





River Idro
16



River Idro
23

Scopri le
caratteristiche
del prodotto
e il tuo risparmio
con il conto
termico

River Idro 16/23

- Linee morbide dal sapore classico contemporaneo
- Stufa idro ventilata
- Rivestimenti in metallo o in pregiata ceramica



- Soft lines with a classic contemporary feel
- Ventilated hydro stove
- Metal cladding or high-quality ceramics

- Des lignes souples avec une touche classique contemporaine
- Poêle hydro ventilé
- Habillages en métal ou céramique précieuse

- Weiche Linien mit klassischem, modernem Look
- Belüfteter wasserführender Ofen
- Verkleidungen aus Metall oder aus wertvoller Keramik



Go Fast*



Wi-Fi
Bluetooth**



Collegam. imp.
riscaldamento***



165/513 (v.16)
165/704 (v.24)



10/33 (v.16)
7/33 (v.24)



kg
40

*** Candeletta di tipo
ceramico che garantisce
un'accensione
più rapida del pellet.**

Glow plug that guarantees
faster pellet ignition.
Bougie de préchauffage
de type céramique qui
garantit un allumage plus
rapide du pellet.
Keramischen Zündkerze
stand, die eine schnellere
Zündung der Pellets.

**** Gestione tramite Wi-Fi
e Bluetooth integrati.**

Control through integrated
Wi-Fi and Bluetooth.
Gestion via Wi-Fi
et Bluetooth intégrés.
Verwaltung über WLAN
und integriertes Bluetooth.

***** Colleg. all'impianto
di riscaldamento.**

Connection to the heating
system. / Raccordement
avec système de
chauffage. / Anschluss zu
Heizungssystem.

18/
24,7 kW





Saturno 16



Saturno 24

Scopri le
caratteristiche
del prodotto
e il tuo risparmio
con il conto
termico

Saturno 16/24









- **Inserto dal design minimale, con ampia visione del fuoco**
- **Disponibile nelle potenze di 16 e 24 kW con ventilazione frontale**
- **Wi-Fi e Bluetooth integrati**



- Insert with a minimalist design, with a large view of the fire
- Available with outputs of 16 and 24 kW with front ventilation
- Built-in Wi-Fi and Bluetooth

- Un insert au design minimaliste, avec une grande vue du feu
- Disponible dans une puissance de 16 et 24 kW avec ventilation frontale
- Wi-Fi et Bluetooth intégrés

- Kamineinsatz mit minimalistischem Design mit guter Sicht auf das Feuer
- Mit 16 und 24 kW Leistung und Frontgebläse erhältlich
- Integrierte WLAN und Bluetooth

			
Classificazione 5 stelle (D.M.186)	Go Fast*	Wi-Fi Bluetooth**	Up, back
			
Collegam, imp. riscaldamento***	137/451 (v.16) 137/627 (v.24)	22	6/22 (v.16) 4/22 (v.24)

* **Candeletta di tipo ceramico che garantisce un'accensione più rapida del pellet.**
Glow plug that guarantees faster pellet ignition.
Bougie de préchauffage de type céramique qui garantit un allumage plus rapide du pellet.
Keramischen Zündkerze stand, die eine schnellere Zündung der Pellets.

** **Gestione tramite Wi-Fi e Bluetooth integrati.**
Control through integrated Wi-Fi and Bluetooth.
Gestion via Wi-Fi et Bluetooth intégrés.
Verwaltung über WLAN und integriertes Bluetooth.

*** **Colleg. all'impianto di riscaldamento.**
Connection to the heating system. / Raccordement avec système de chauffage. / Anschluss zu Heizungssystem.

16,1/
22,4 kW





Maya Idro 16



Maya Idro 24

Scopri le
caratteristiche
del prodotto
e il tuo risparmio
con il conto
termico

Maya Idro 16/24



- Disponibile nelle potenze di 16 e 24 kW
- Ventilata e pensata per gli spazi ristretti
- Rivestimento in metallo in vari colori

- Available with outputs of 16 and 24 kW
- Ventilated and designed for confined spaces
- Metal cladding in various colours
- Disponible dans les puissances 16 et 24 kW
- Ventilé et conçu pour les petits espaces
- Habillages en métal de différentes couleurs
- Mit 16 und 24 kW Leistung erhältlich
- Belüftet und für enge Platzverhältnisse gedacht
- Metallverkleidung in mehreren Farben



*** Valvola anti-fumo**
Anti-smoke valve
Valve anti-fumée
Rauchgasklappe

7/7,5 kW



Classificazione
5 stelle (D.M.186)



Classificazione
4 stelle (D.M.186)



Valvola
anti-fumo*



Up



196
210 (v.8)



1,9
2 (v.8)





Hublot 7



Hublot 8

Scopri le
caratteristiche
del prodotto
e il tuo risparmio
con il conto
termico



Hublot 7/8

Wood/Wood Air



- Atmosfera accogliente e romantica davanti al calore del fuoco
- Camera sagomata per ceppi fino a 50 cm
- Porta, top e piedini in ghisa
- Valvola antifumo

- Cosy and romantic atmosphere by the warming fireplace
- Shaped chamber for logs up to 50 cm
- Cast iron door, top and feet
- Smoke valve
- Ambiance chaleureuse et romantique devant la chaleur du feu
- Chambre de forme pour les bûches jusqu'à 50 cm
- Porte, couvercle et pieds en fonte
- Clapet anti-fumée
- Gemütliche Atmosphäre vor dem Feuer.
- Geförmten Kammer für Holzscheite bis zu 50 cm
- Tür, Topplatte und Füße aus Gusseisen
- Rauchgasklappe



Classificazione
5 stelle (D.M.186)



Classificazione
4 stelle (D.M.186)



Up



224 (v.8)
252 (v.9)



2,2 (v.8)
2,5 (v.9)

8/9 kW





Spin 8



Spin 9

Scopri le **caratteristiche del prodotto** e il tuo risparmio con il **conto termico**

- Camera di combustione per ceppi fino a 33 cm
- Doppia combustione
- Disponibile sia ventilata che a convezione naturale

Spin 8/9

Wood/Wood Air



- Combustion chamber for up to 33 cm logs
- Dual combustion
- Available in both ventilated and natural convection versions

- Chambre de combustion pour bûches jusqu'à 33 cm
- Double combustion
- Disponible en version ventilée et convection naturelle

- Brennkammer für Holzsplitte bis 33 cm
- Doppelter Verbrennung
- Erhältlich belüftete und mit natürlicher Konvektion



Built-in



Free Standing



Up, back

6,5/
7,5 kW



185 (v.60)
214 (v.80)



L 30 (v.60)
L 33 (v.80)





Smart 60



Smart 80

Scopri le
caratteristiche
del prodotto
e il tuo risparmio
con il conto
termico

Smart 60/80



- **Porte in ghisa, eleganti maniglie e corrimano in acciaio**
- **Da incasso e a libera installazione**
- **Con piedini estetici o zoccolo in acciaio**

- Cast iron doors, elegant handles and steel handrail
- Recessed or free installation
- With aesthetic feet or steel basement
- Portes en fonte, poignées élégantes et mains courantes en acier
- Encastrable ou en pose libre
- Avec pieds décoratifs ou socle en acier
- Türen aus Gusseisen, elegante Griffe und Handlauf aus Stahl
- Zum Einbau oder freistehend
- Mit Zierfüßen oder Stahlsockel





Built-in



Up, back



177 (v.60)
214 (v.80/90)



L 33

6,2/
7,5 kW





Kook 60



Kook 80



Kook 90

Scopri le **caratteristiche del prodotto** e il tuo risparmio con il **conto termico** (versione Kook 80)

- **Da incasso**
- **Camera di combustione con interno in refrattario**
- **Ampio vetro per vista sul forno**

Kook 60/80/90

- Built-in
- Combustion chamber with refractory stone interior
- Large glass window offering a view on the oven
- Encastrable
- Chambre de combustion avec intérieur en matériau réfractaire
- Grande vitre pour une meilleure vue du four
- Zum Einbau
- Brennkammer mit feuerbeständigem Innenraum
- Große Glasscheibe für den Blick aufs Feuer







Technical features

Pellet Air

Stufe ad aria ventilata
dotate di camera
stagna, con potenze
da 5 a 10,5 kW

Stove with ventilated
air and sealed chamber,
with outputs from
5 to 10,5 kW

Poêles à air ventilé
avec chambre étanche,
puissance de 5 à 10,5 kW

Luftführende belüftete
Öfen mit abgedichteter
Kammer und Leistung
zwischen 5 und 10,5 kW

Spirit 5 ● 5,1 kW P. 16



Scopri le
caratteristiche
e il risparmio
del **conto**
termico

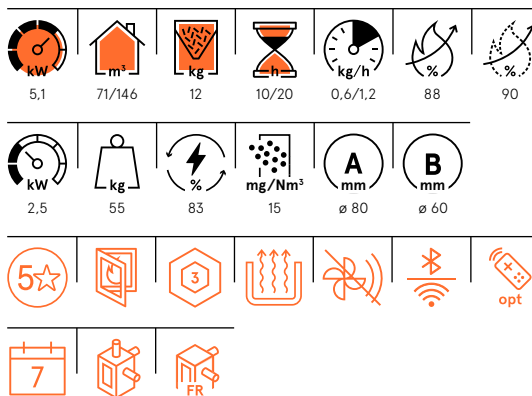
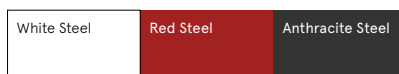
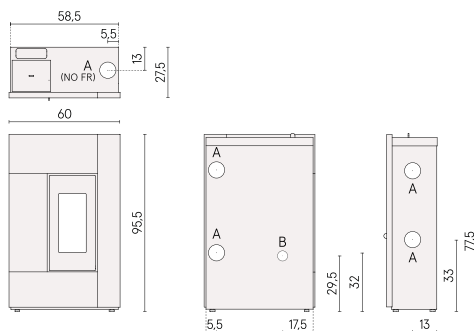
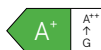

European standards
Art. 15A B-VG 2015
BImSchV 2015
Regensburg

München
Stuttgart
Aachen
EN 16510:2022

CE
Certificate model name:
SPIRIT 5 T2



Spirit 5 Up

● 5,1 kW

P. 16



Scopri le **caratteristiche** e il risparmio del **conto termico**

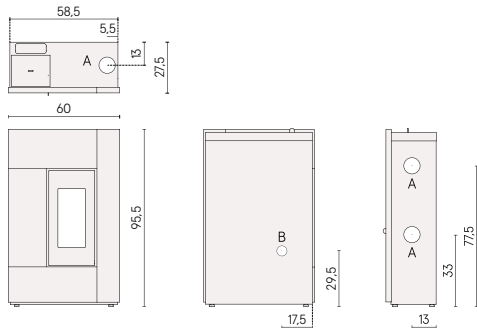
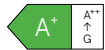

White Steel Anthracite Steel

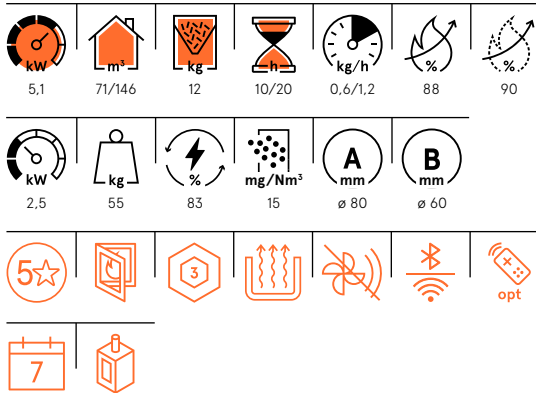

European standards
Art. 15A B-VG 2015
BImSchV 2015
Regensburg

München
Stuttgart
Aachen
EN 16510:2022



Certificate model name:
SPIRIT 5 UP T2



Sound 5 Ps

● 5,5 kW

P. 18



Scopri le **caratteristiche** e il risparmio del **conto termico**

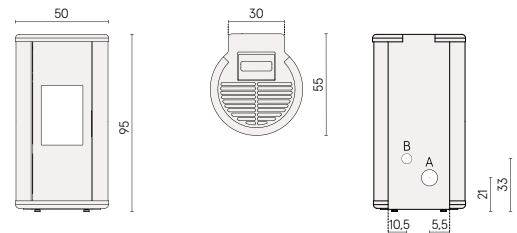

Anthracite Steel

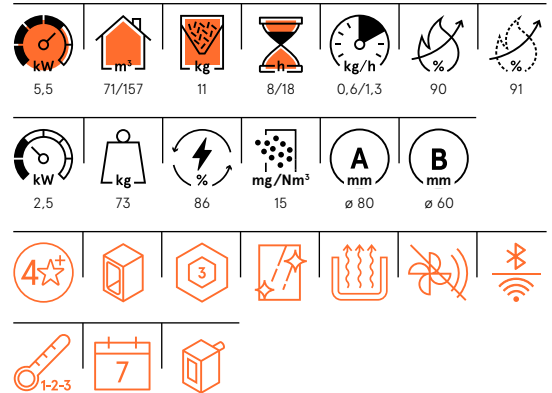

European standards
BImSchV 2015
Regensburg
München

Stuttgart
Aachen
EN 16510:2022



Certificate model name:
SOUND 5 PS



Sound 7 Ps

● 7 kW

P. 18



Scopri le **caratteristiche** e il risparmio del **conto termico**

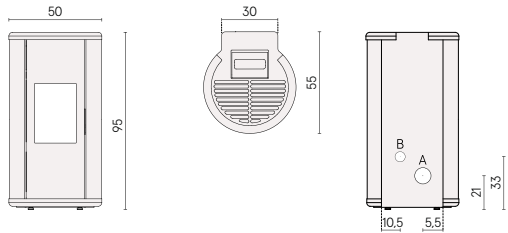

Anthracite Steel

7	83/200	11	6/18	0,6/1,7	89	90
2,9	73	85	15	ø 80	ø 60	

European standards
BImSchV 2015
Regensburg
München

Stuttgart
Aachen
EN 16510:2022

CE
Certificate model name:
SOUND 7 PS T2



Sound 5 Up-Twin

● 5,5 kW

P. 18



Scopri le **caratteristiche** e il risparmio del **conto termico**

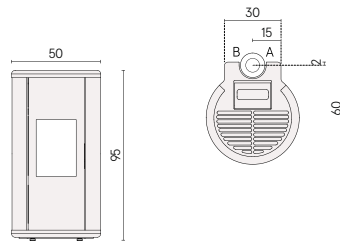

White Steel Titanium Steel Anthracite Steel

5,5	71/157	11	8/18	0,6/1,3	90	91
2,5	76	86	15	ø 80	ø 130	

European standards
Art. 15A B-VG 2015
BImSchV 2015
Regensburg

München
Stuttgart
Aachen
EN 16510:2022

CE
Certificate model name:
SOUND3 5 UP



Sound 7 Up-Twin

● 7 kW

P. 18



Scopri le **caratteristiche** e il risparmio del **conto termico**

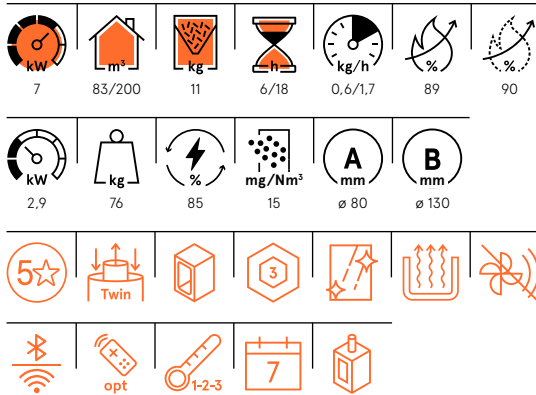
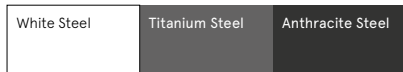
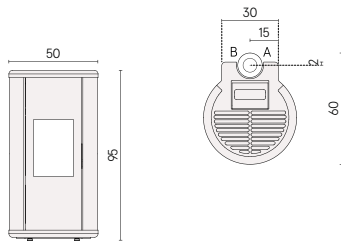
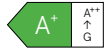

European standards
Art. 15A B-VG 2015
BImSchV 2015
Regensburg

München
Stuttgart
Aachen
EN 16510:2022



Certificate model name:
SOUND 7 UP-TWIN T2



Hublot 6 Up-Twin

● 6 kW

P. 20



Scopri le **caratteristiche** e il risparmio del **conto termico**

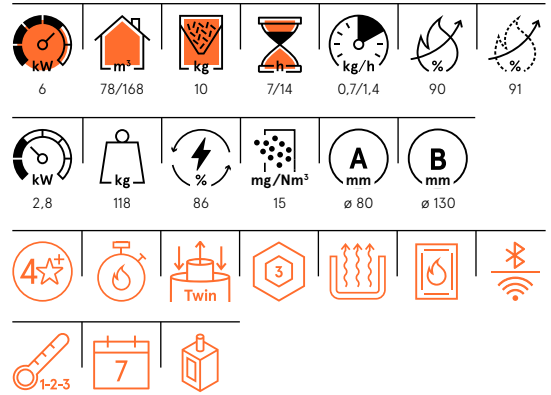
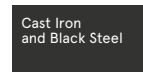
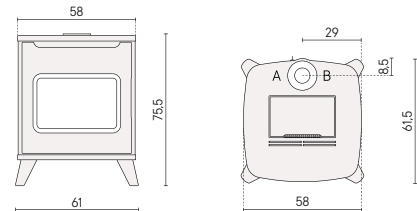

European standards
Art. 15A B-VG 2015
BImSchV 2015
Regensburg

München
Stuttgart
Aachen
EN 16510:2022



Certificate model name:
HUBLOT 6 UP T1



Magritte 6

● 6 kW

P. 22



Scopri le **caratteristiche** e il risparmio del **conto termico**

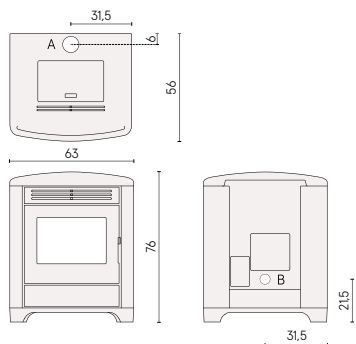
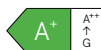

Cast Iron and Black Steel

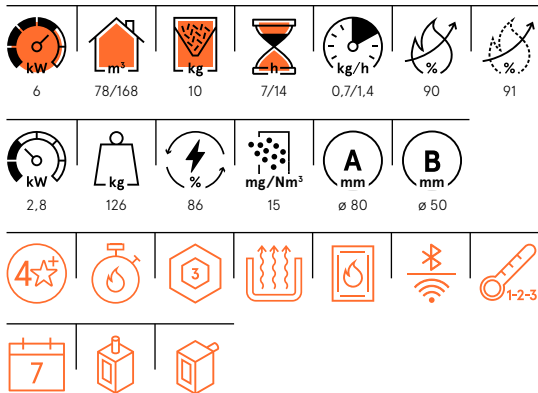

European standards
Art. 15A B-VG 2015
BImSchV 2015
Regensburg

München
Stuttgart
Aachen
EN 16510:2022

CE
Certificate model name:
MAGRITTE 6 T1



Cristal 6

● 5,5 kW

P. 24



Scopri le **caratteristiche** e il risparmio del **conto termico**

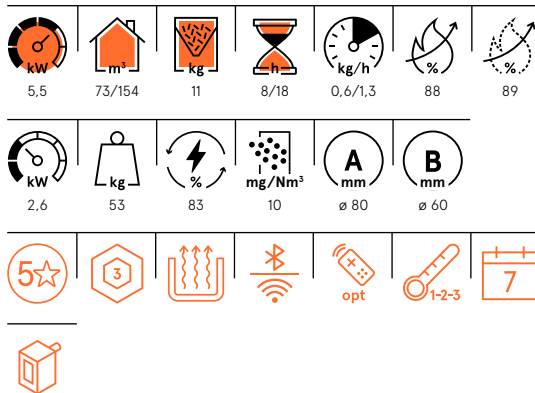
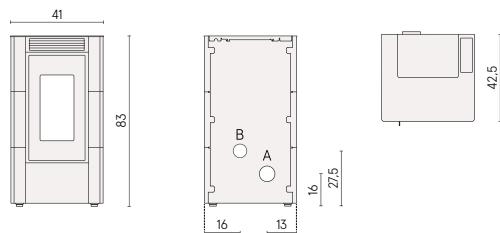

European standards
Art. 15A B-VG 2015
BImSchV 2015
Regensburg

München
Stuttgart
Aachen
EN 16510:2022

CE
Certificate model name:
CRISTAL 6 T1



Cristal 7

● 7 kW

P. 26



Scopri le **caratteristiche** e il risparmio del **conto termico**

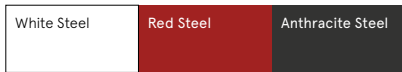
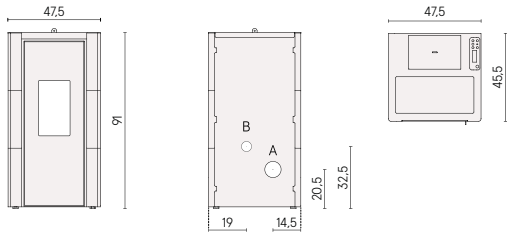
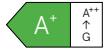

7	83/200	15	9/25	0,6/1,7	89	90
2,9	56	85	15	ø 80	ø 60	

European standards
Art. 15A B-VG 2015
BImSchV 2015
Regensburg

München
Stuttgart
Aachen
EN 16510:2022



Certificate model name:
CRISTAL 7 T2



Cristal 7 Up

● 7 kW

P. 26



Scopri le **caratteristiche** e il risparmio del **conto termico**

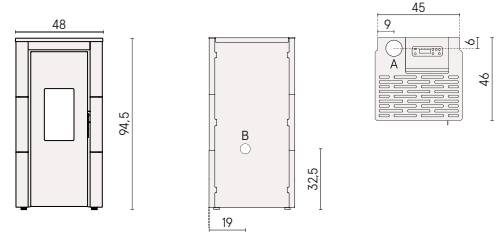

7	83/200	12	7/20	0,6/1,7	89	90
2,9	65	85	15	ø 80	ø 60	

European standards
Art. 15A B-VG 2015
BImSchV 2015
Regensburg

München
Stuttgart
Aachen
EN 16510:2022



Certificate model name:
CRISTAL 7 UP T2



Grace 7

6,9 kW
P. 28



Scopri le **caratteristiche** e il risparmio del **conto termico**



Upgrade

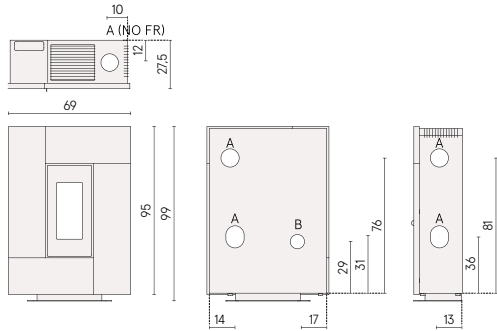

White Steel	Light Bronze Steel	Black Glass
Red Steel	Anthracite Steel	Serpentino Stone

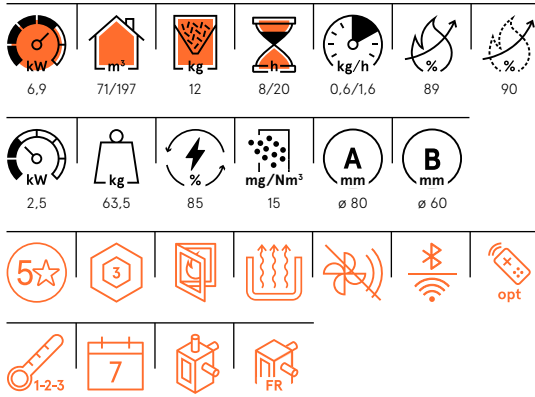

European standards
Art. 15A B-VG 2015
BImSchV 2015
Regensburg

München
Stuttgart
Aachen
EN 16510:2022



Certificate model name:
GRACE 7 T2



Grace 7 Up

6,9 kW
P. 28



Scopri le **caratteristiche** e il risparmio del **conto termico**



Upgrade

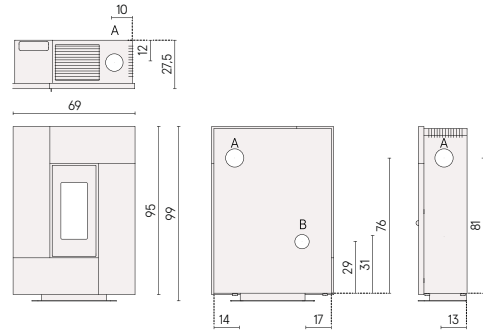

White Steel	Light Bronze Steel	Black Glass
Red Steel	Anthracite Steel	Serpentino Stone

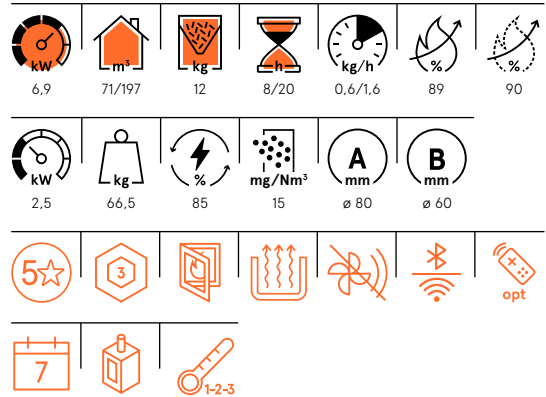

European standards
Art. 15A B-VG 2015
BImSchV 2015
Regensburg

München
Stuttgart
Aachen
EN 16510:2022



Certificate model name:
GRACE 7 UP T2



Grace 7 Up-Twin

6,9 kW

P. 28



Scopri le **caratteristiche** e il risparmio del **conto termico**

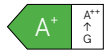

Upgrade

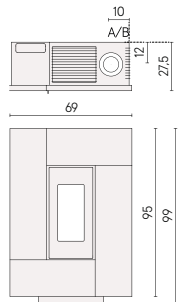

White Steel	Light Bronze Steel	Black Glass
Red Steel	Anthracite Steel	Serpentino Stone

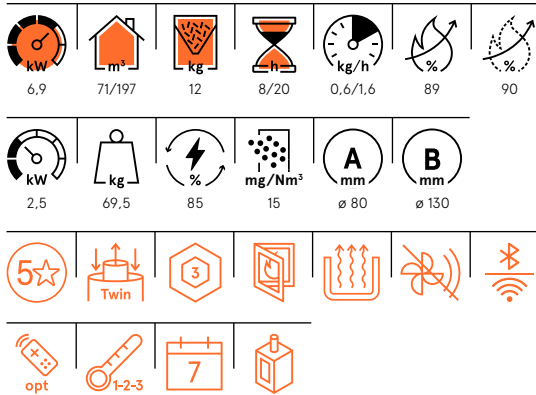

European standards
Art. 15A B-VG 2015
BImSchV 2015
Regensburg

München
Stuttgart
Aachen
EN 16510:2022



Certificate model name:
GRACE 7 UP-TWIN T2



Baggy 7

6,9 kW

P. 30



Scopri le **caratteristiche** e il risparmio del **conto termico**

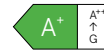

New

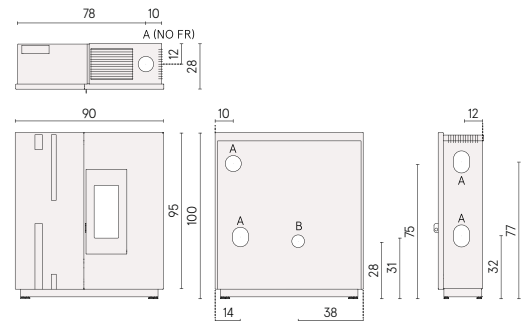

Titanium Steel	Black Steel
----------------	-------------

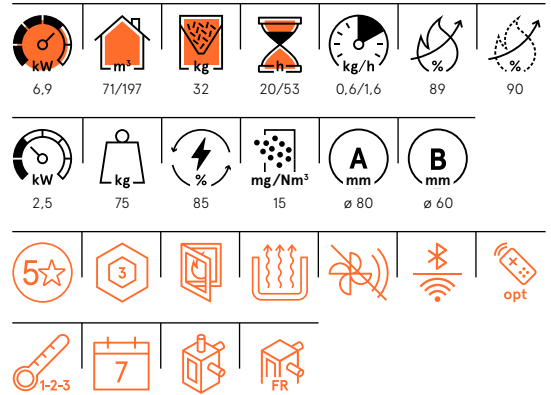

European standards
Art. 15A B-VG 2015
BImSchV 2015
Regensburg

München
Stuttgart
Aachen
EN 16510:2022



Certificate model name:
BAGGY 7 T2



Baggy 7 Up

● 6,9 kW

P. 30



Scopri le **caratteristiche** e il risparmio del **conto termico**

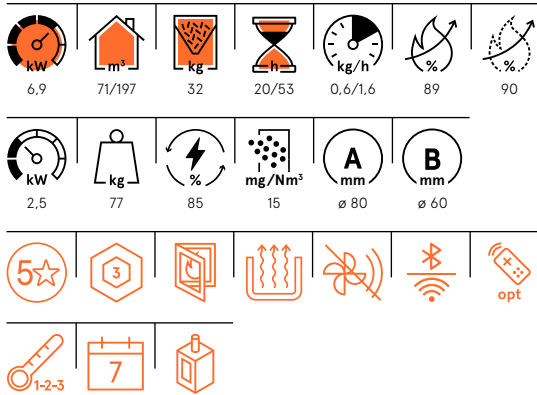
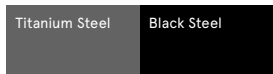
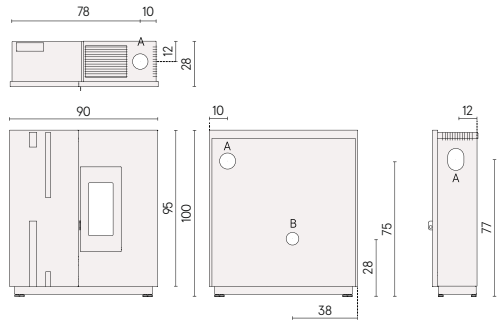

European standards
Art. 15A B-VG 2015
BImSchV 2015
Regensburg

München
Stuttgart
Aachen
EN 16510:2022



Certificate model name:
BAGGY 7 UP T2



Baggy 7 Up-Twin

● 6,9 kW

P. 30



Scopri le **caratteristiche** e il risparmio del **conto termico**

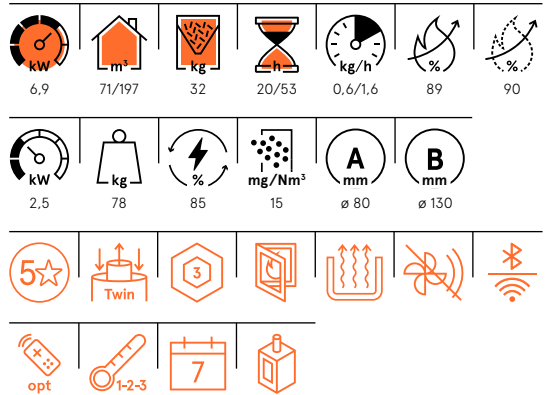
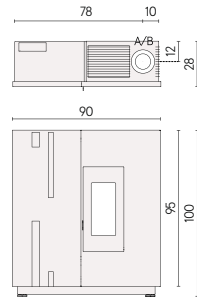

European standards
Art. 15A B-VG 2015
BImSchV 2015
Regensburg

München
Stuttgart
Aachen
EN 16510:2022



Certificate model name:
BAGGY 7 UP-TWIN T2



Bold 7

● 7 kW
P. 32



Scopri le **caratteristiche** e il risparmio del **conto termico**

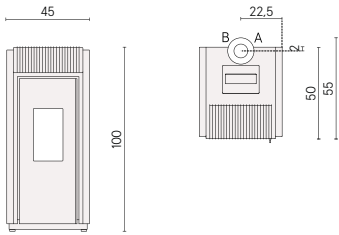

White Steel	Titanium Steel	Anthracite Steel
-------------	----------------	------------------

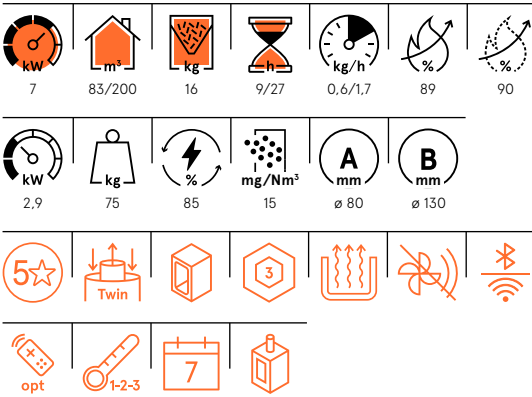

European standards
Art. 15A B-VG 2015
BImSchV 2015
Regensburg

München
Stuttgart
Aachen
EN 16510:2022



Certificate model name:
BOLD 7 UP-TWIN T2



Perla 7

● 7 kW
P. 34



Scopri le **caratteristiche** e il risparmio del **conto termico**

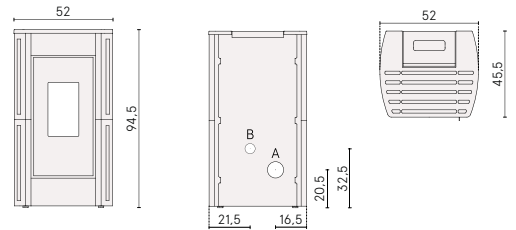

White Majolica	Ivory Majolica	Red Majolica
White Steel	Red Steel	Anthracite Steel

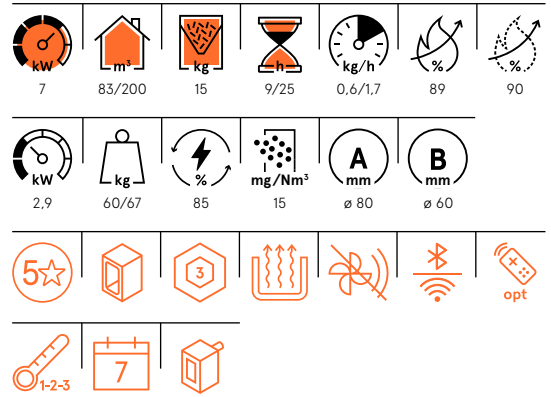

European standards
Art. 15A B-VG 2015
BImSchV 2015
Regensburg

München
Stuttgart
Aachen
EN 16510:2022



Certificate model name:
PERLA 7 T2



Sweet 7

● 7 kW

P. 36



Scopri le **caratteristiche** e il risparmio del **conto termico**

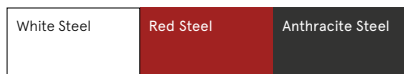
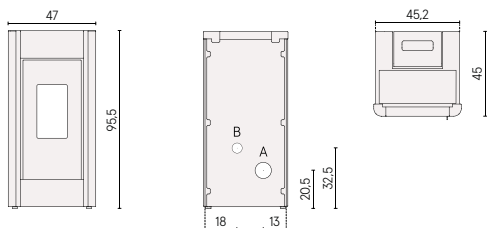
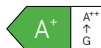

7	83/200	15	9/25	0,6/1,7	89	% icon"/> 90
2,9	56	85	15	ø 80	ø 60	

European standards
Art. 15A B-VG 2015
BimSchV 2015
Regensburg

München
Stuttgart
Aachen
EN 16510:2022

CE
Certificate model name:
SWEET 7 T2



Ponente 7

● 7 kW

P. 38



Scopri le **caratteristiche** e il risparmio del **conto termico**

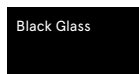
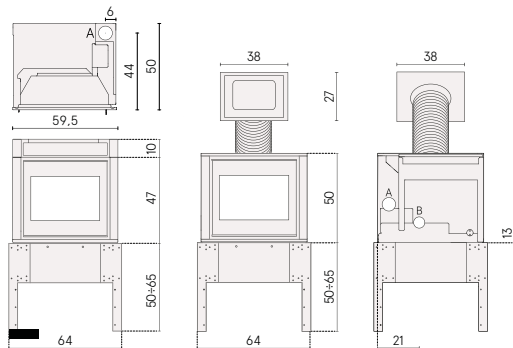
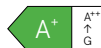

7	92/190	8	5/11	0,7/1,6	88	% icon"/> 90
3,3	73	83	15	ø 80	ø 60	

European standards
Art. 15A B-VG 2015
BimSchV 2015
Regensburg

München
Stuttgart
Aachen
EN 16510:2022

CE
Certificate model name:
PONENTE 7 T1



Cristal 9

● 8,5 kW
P. 48



Scopri le **caratteristiche** e il risparmio del **conto termico**



Cristal 9 Air

● 8,5 kW
P. 50



Scopri le **caratteristiche** e il risparmio del **conto termico**



Upgrade

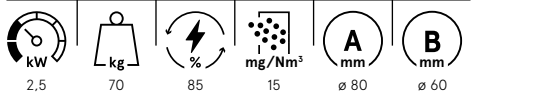
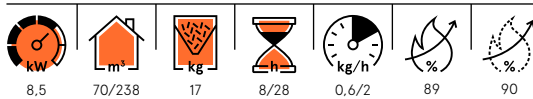
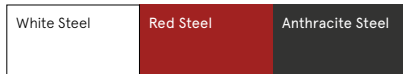
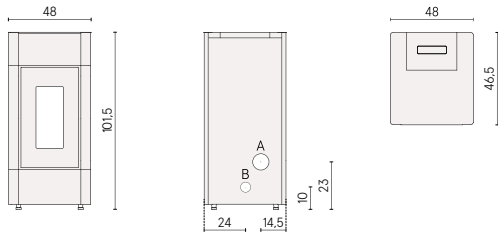

European standards
Art. 15A B-VG 2015
BImSchV 2015
Regensburg

München
Stuttgart
Aachen
EN 16510:2022



Certificate model name:
CRISTAL 9 T1

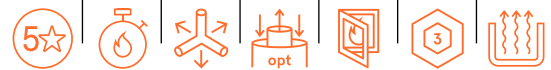
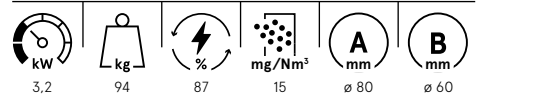
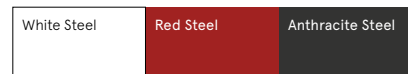
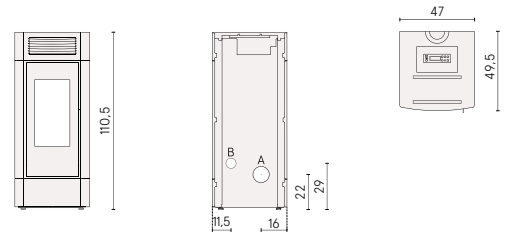

European standards
Art. 15A B-VG 2015
BImSchV 2015
Regensburg

München
Stuttgart
Aachen
EN 16510:2022



Certificate model name:
CRISTAL 9 AIR T1



Cristal 9 Airtech

● 8,5 kW

P. 48



Scopri le **caratteristiche** e il risparmio del **conto termico**

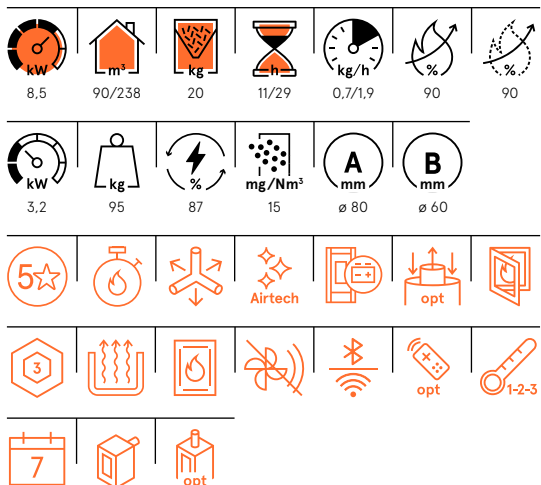
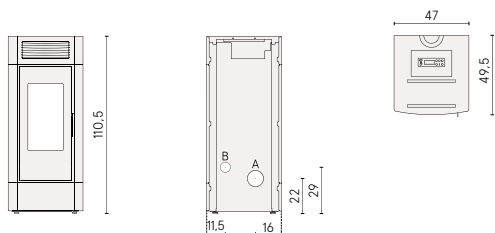
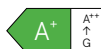

European standards
Art. 15A B-VG 2015
BImSchV 2015
Regensburg

München
Stuttgart
Aachen
EN 16510:2022

CE
Certificate model name:
CRISTAL 9 AIRTECH T1



Quasimodo 9

Box Up-Twin/Up-Twin

● 9 kW

P. 40



Box Up-Twin



Up-Twin

Scopri le **caratteristiche** e il risparmio del **conto termico**

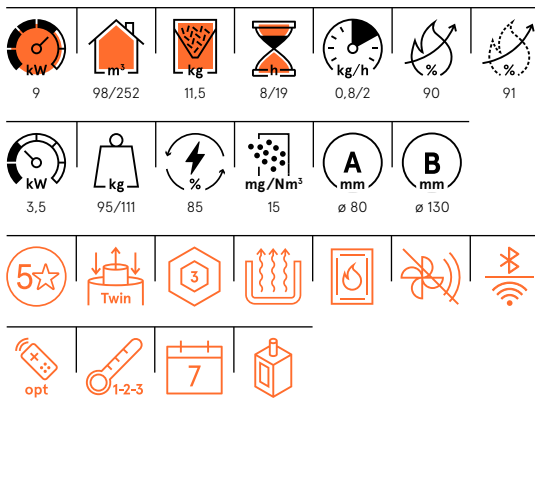
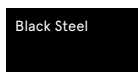
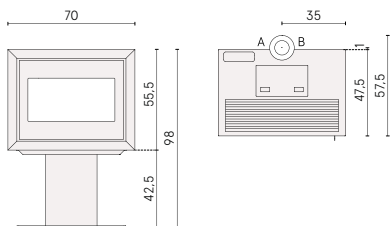
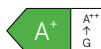

European standards
Art. 15A B-VG 2015
BImSchV 2015
Regensburg

München
Stuttgart
Aachen
EN 16510:2022

CE
Certificate model name:
QUASIMODO 9
UP-TWIN T2



Zefiro 9

● 9 kW

P. 42



Scopri le **caratteristiche** e il risparmio del **conto termico**

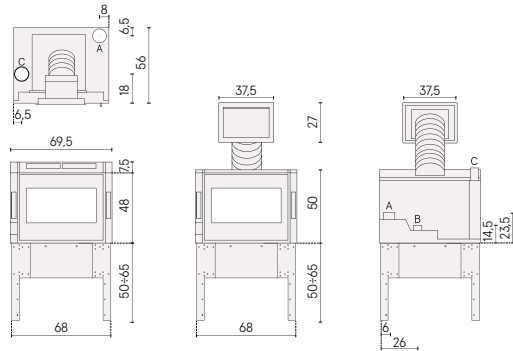

Black Glass

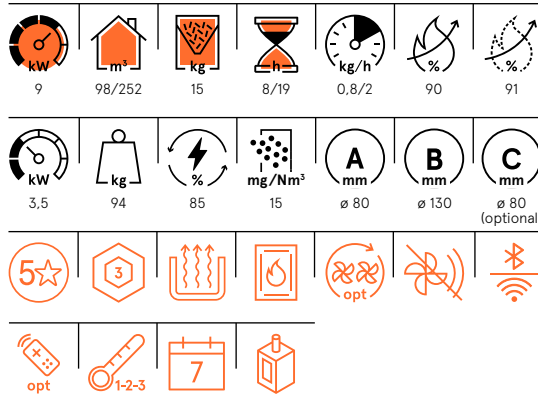

European standards
BImSchV 2015
Regensburg
München

Stuttgart
Aachen
EN 16510:2022



Certificate model name:
ZEFIRO 9 T2



Frame 9 Ps

● 9 kW

P. 44



Scopri le **caratteristiche** e il risparmio del **conto termico**

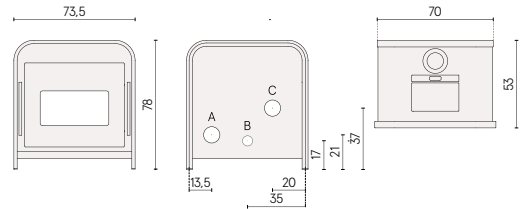

Light Bronze Steel

Black Steel

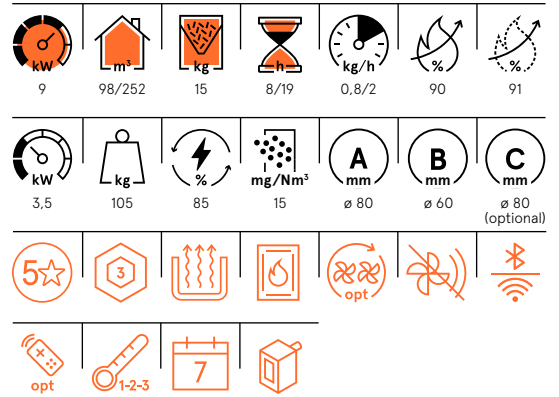

European standards
BImSchV 2015
Regensburg
München

Stuttgart
Aachen
EN 16510:2022



Certificate model name:
FRAME 9 T2



Frame 9 Up-Twin

● 9 kW

P. 44



Scopri le **caratteristiche** e il risparmio del **conto termico**

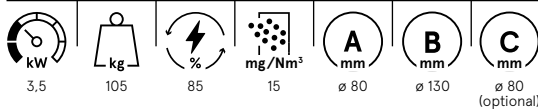
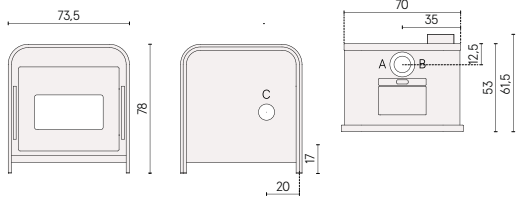

European standards
BImSchV 2015
Regensburg
München

Stuttgart
Aachen
EN 16510:2022

CE
Certificate model name:
FRAME 9 UP-TWIN T2



Shell 9 Up-Twin

● 9,1 kW

P. 46



Scopri le **caratteristiche** e il risparmio del **conto termico**

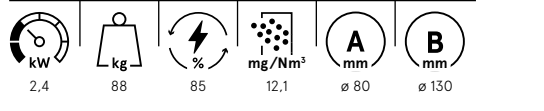
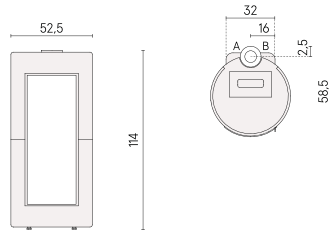

European standards
Art. 15A B-VG 2015
BImSchV 2015
Regensburg

München
Stuttgart
Aachen
EN 16510:2022

CE
Certificate model name:
SHELL 3 UP



Prince 11

10,5 kW

P. 64



Scopri le **caratteristiche** e il risparmio del **conto termico**

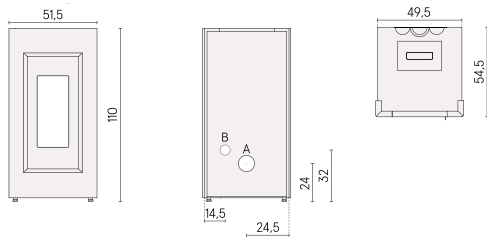

White Steel	Light Bronze Steel	Titanium Steel
Red Steel	Anthracite Steel	

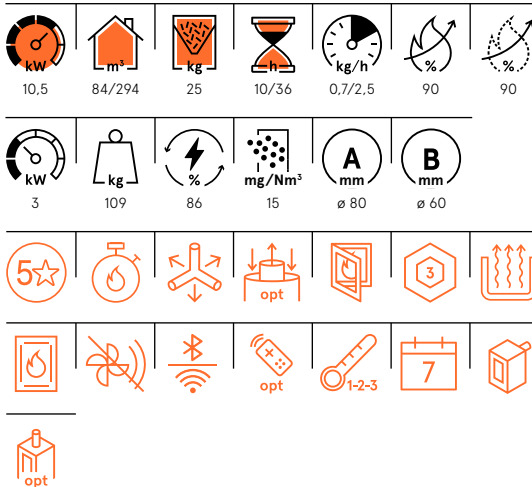

European standards
Art. 15A B-VG 2015
BlmSchV 2015
Regensburg

München
Stuttgart
Aachen
EN 16510:2022



Certificate model name:
PRINCE 11 T1



Kobe 11

10,5 kW

P. 66



Scopri le **caratteristiche** e il risparmio del **conto termico**

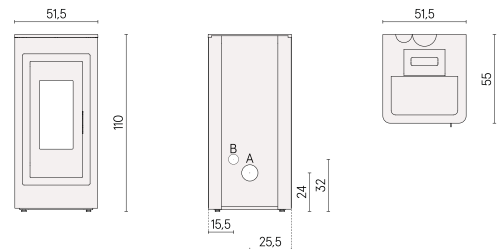

White Steel	Light Bronze Steel	Titanium Steel
Red Steel	Anthracite Steel	

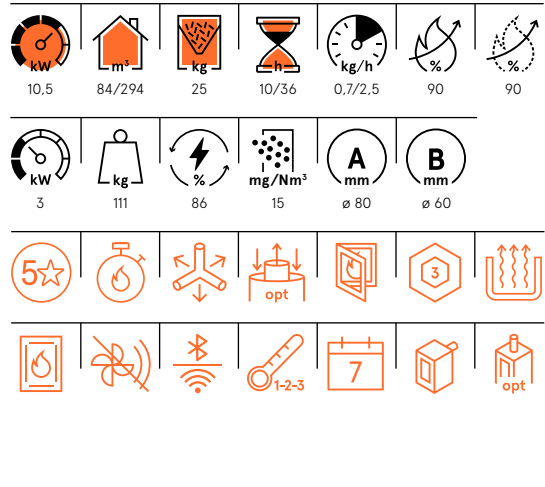

European standards
Art. 15A B-VG 2015
BlmSchV 2015
Regensburg

München
Stuttgart
Aachen
EN 16510:2022



Certificate model name:
KOBÉ 11 T1



Fenice 11

● 10,5 kW

P. 68



Scopri le **caratteristiche** e il risparmio del **conto termico**

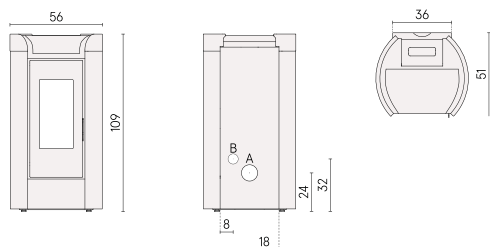
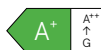

White - gold	Anthracite - titanium	Titanium - anthracite
--------------	-----------------------	-----------------------

10,5	84/294	20	8/29	0,7/2,5	90	90
3	130	86	15	A ø 80	B ø 60	
			1-2-3	7		

European standards
Art. 15A B-VG 2015
BImSchV 2015
Regensburg

München
Stuttgart
Aachen
EN 16510:2022

CE
Certificate model name:
FENICE 11 T1



Pellet Air Plus

Stufe canalizzabili per riscaldare più ambienti della casa in modo omogeneo e in economia, con potenze da 8,5 a 13,7 kW

Ductable stoves to heat several rooms in the house evenly and inexpensively, with outputs from 8,5 to 13,7 kW

Poêles canalisables pour chauffer plusieurs pièces d'une habitation de façon homogène et à petit prix, puissance de 8,5 à 13,7 kW

Kanaliserbare Öfen zum gleichmäßigen und wirtschaftlichen Beheizen von mehreren Räumen, mit Leistungen zwischen 8,5 und 13,7 kW

Cristal Plus 9

● 8,5 kW

P. 48



Scopri le caratteristiche e il risparmio del conto termico

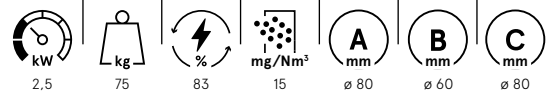
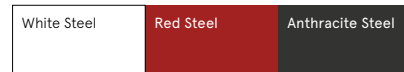
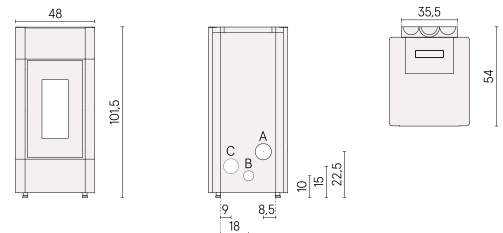

European standards
Art. 15A B-VG 2015
BImSchV 2015
Regensburg

München
Stuttgart
Aachen
EN 16510:2022

CE
Certificate model name:
CRISTAL PLUS 9 T1



Spin Plus 9 Airtech Up-Twin

● 8,5 kW

P. 52



Scopri le caratteristiche e il risparmio del conto termico



Spin Plus 9 Airtech Ps

● 8,5 kW

P. 52



Scopri le caratteristiche e il risparmio del conto termico

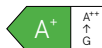

Upgrade

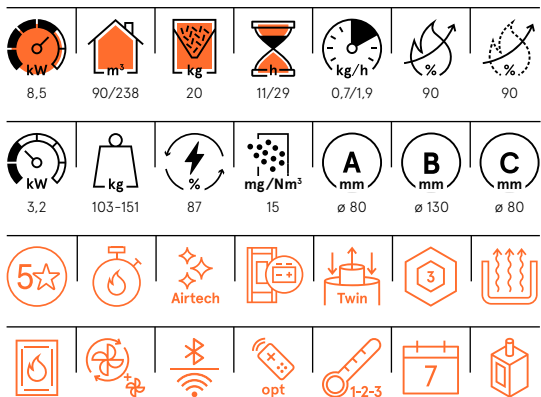
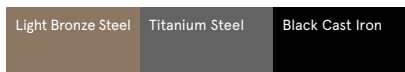
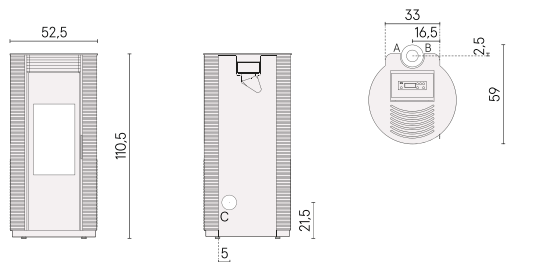

European standards
Art. 15A B-VG 2015
BImSchV 2015
Regensburg

München
Stuttgart
Aachen
EN 16510:2022

CE
Certificate model name:
SPIN PLUS 9 UP-TWIN T1

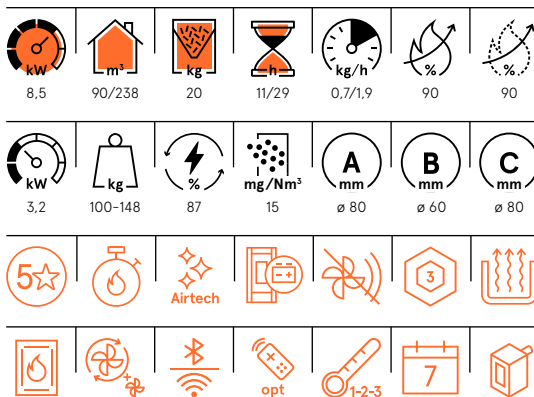
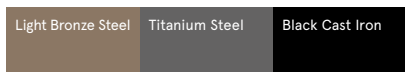
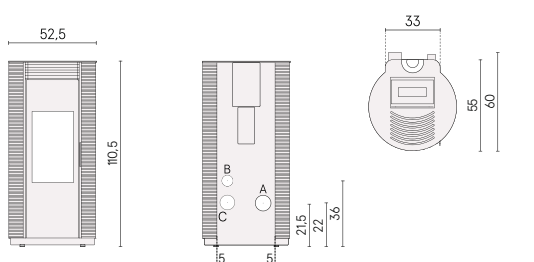

European standards
Art. 15A B-VG 2015
BImSchV 2015
Regensburg

München
Stuttgart
Aachen
EN 16510:2022

CE
Certificate model name:
SPIN PLUS 9 T1



Icon Plus 9

● 8,5 kW

P. 54



Scopri le **caratteristiche** e il risparmio del **conto termico**

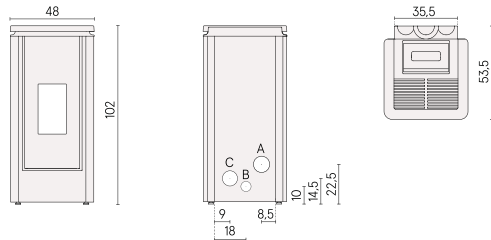

White Steel	Light Bronze Steel	Titanium Steel	Anthracite Steel
-------------	--------------------	----------------	------------------

8,5	70/238	17	8/28	0,6/2,1	87	90
2,5	87	83	15	ø 80	ø 60	ø 80

European standards
Art. 15A B-VG 2015
BlmSchV 2015
Regensburg

München
Stuttgart
Aachen
EN 16510:2022

CE
Certificate model name:
ICON PLUS 9 TI



Luce Plus 9 Up-Twin

● 8,5 kW

P. 56



Scopri le **caratteristiche** e il risparmio del **conto termico**

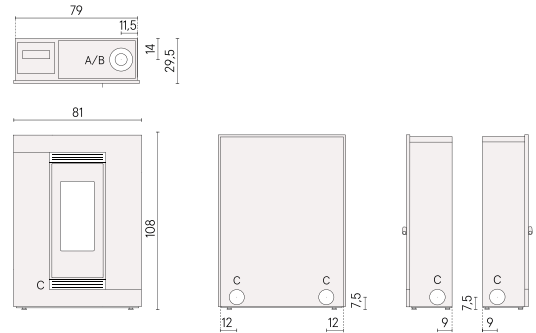

White Steel	Light Bronze Steel	Titanium Steel
Anthracite Steel	Serpentino Stone	

8,5	92/238	15	8/21	0,7/2	89	89
3,3	97/119	86	15	ø 80	ø 130	ø 80

European standards
Art. 15A B-VG 2015
BlmSchV 2015
Regensburg

München
Stuttgart
Aachen
EN 16510:2022

CE
Certificate model name:
LUCE PLUS 9 UP-TWIN T2



Luce Plus Flexit

● 8,5 kW

P. 56



Scopri le **caratteristiche** e il risparmio del **conto termico**

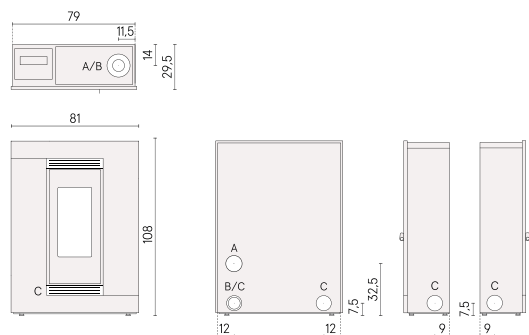
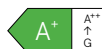

White Steel	Light Bronze Steel	Titanium Steel
Anthracite Steel	Serpentino Stone	



European standards
Art. 15A B-VG 2015
BImSchV 2015
Regensburg

München
Stuttgart
Aachen
EN 16510:2022

CE
Certificate model name:
LUCÉ PLUS 9 T2



Elle Plus 9 Up-Twin

● 8,5 kW

P. 58



Scopri le **caratteristiche** e il risparmio del **conto termico**

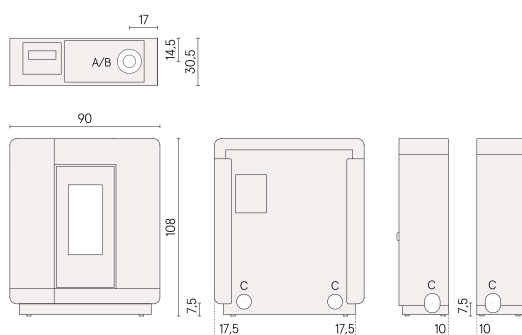

Light Bronze Steel	Ossido Bruno Stone	Nero Greco Stone
Titanium Steel	Black Glass	

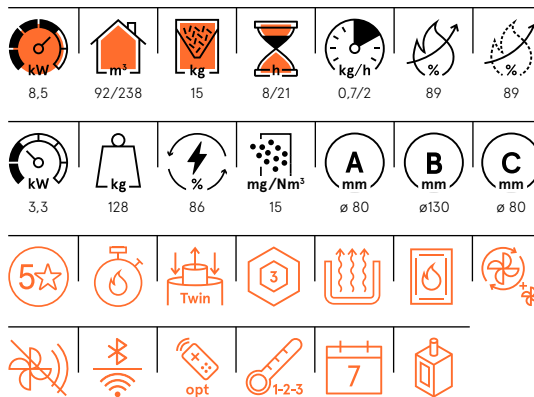

European standards
Art. 15A B-VG 2015
BImSchV 2015
Regensburg

München
Stuttgart
Aachen
EN 16510:2022

CE
Certificate model name:
ELLE PLUS 9 UP-TWIN T2



Elle Plus 9 Flexit

● 8,5 kW

P. 58



Scopri le **caratteristiche** e il risparmio del **conto termico**

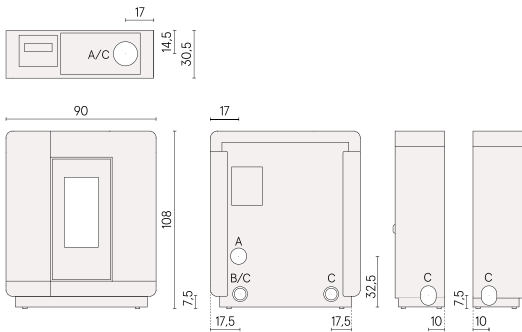

Light Bronze Steel	Ossido Bruno Stone	Nero Greco Stone
Titanium Steel	Black Glass	

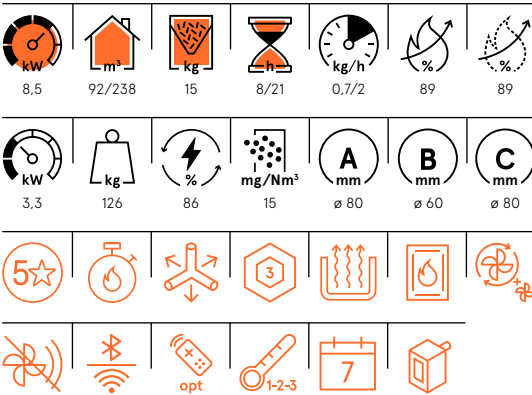

European standards
Art. 15A B-VG 2015
BImSchV 2015
Regensburg

München
Stuttgart
Aachen
EN 16510:2022



Certificate model name:
ELLE PLUS 9 T2



Wall Plus 10 ● 10 kW

P. 60



Scopri le **caratteristiche** e il risparmio del **conto termico**

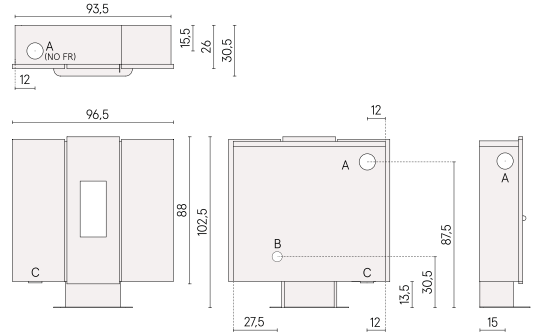

White Steel	Red Steel
-------------	-----------

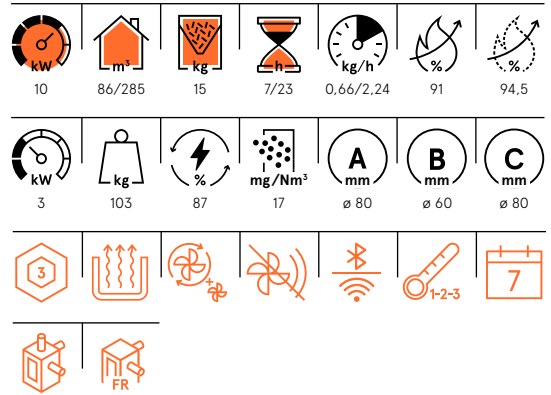

European standards
Art. 15A B-VG 2015
BImSchV 2015
Regensburg

München
Stuttgart
Aachen
EN 16510:2022



Certificate model name:
WALL³ PLUS



Tile Plus 10

● 10 kW

P. 62



Scopri le **caratteristiche** e il risparmio del **conto termico**

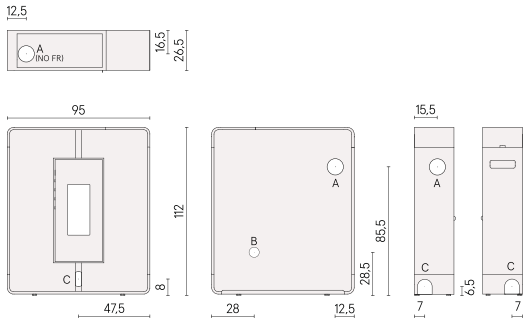

White Steel	Light Bronze Steel	Titanium Steel
Red Steel	Anthracite Steel	

10	86/285	18	8/27	0,66/2,24	91	% icon"/> 94,5
3	130	87	17	ø 80	ø 60	ø 80

European standards
Art. 15A B-VG 2015
BImSchV 2015
Regensburg

München
Stuttgart
Aachen
EN 16510:2022

CE
Certificate model name:
TILE^S PLUS



Prince Plus 11

● 10,5 kW

P. 64



Scopri le **caratteristiche** e il risparmio del **conto termico**

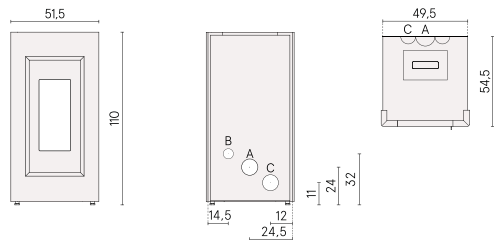

White Steel	Light Bronze Steel	Titanium Steel
Red Steel	Anthracite Steel	

10,5	84/294	25	10/36	0,7/2,5	88	% icon"/> 90
3	112	84	15	ø 80	ø 60	ø 80

European standards
Art. 15A B-VG 2015
BImSchV 2015
Regensburg

München
Stuttgart
Aachen
EN 16510:2022

CE
Certificate model name:
PRINCE PLUS 11 T1



Kobe Plus 11

● 10,5 kW

P. 66



Scopri le **caratteristiche** e il risparmio del **conto termico**

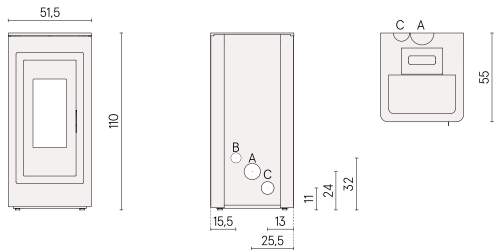

White Steel Light Bronze Steel Titanium Steel
 Red Steel Anthracite Steel

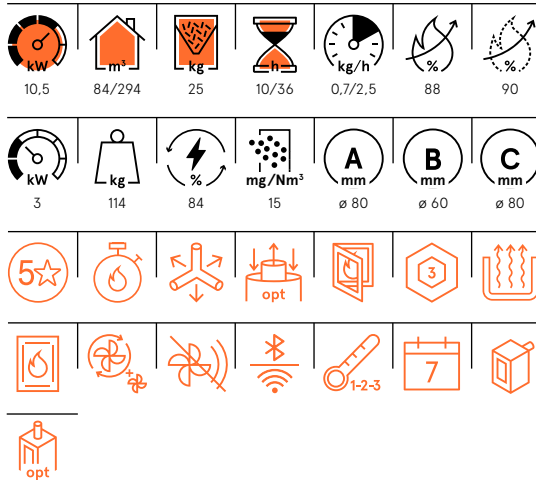

European standards
 Art. 15A B-VG 2015
 BImSchV 2015
 Regensburg

München
 Stuttgart
 Aachen
 EN 16510:2022

CE
 Certificate model name:
 KOBE PLUS 11 T1



Fenice Plus 11

● 10,5 kW

P. 68



Scopri le **caratteristiche** e il risparmio del **conto termico**

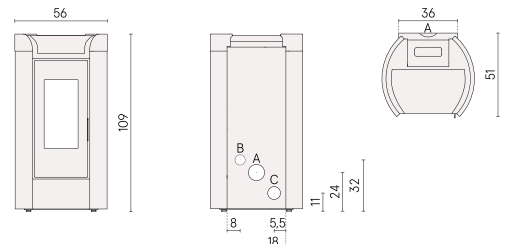

White - gold Anthracite - titanium Titanium - anthracite

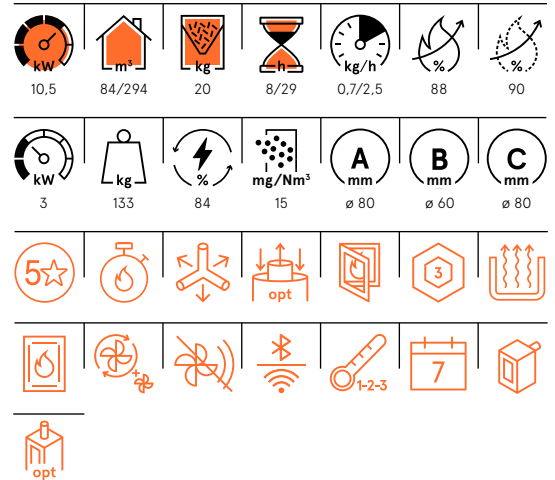

European standards
 Art. 15A B-VG 2015
 BImSchV 2015
 Regensburg

München
 Stuttgart
 Aachen
 EN 16510:2022

CE
 Certificate model name:
 FENICE PLUS 11 T1



Eclipse Plus 11

● 10,5 kW

P. 70



Scopri le **caratteristiche** e il risparmio del **conto termico**

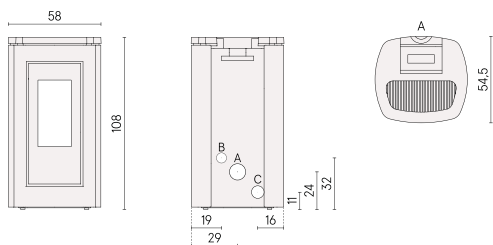
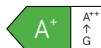

Anthracite - titanium	Titanium - anthracite
-----------------------	-----------------------

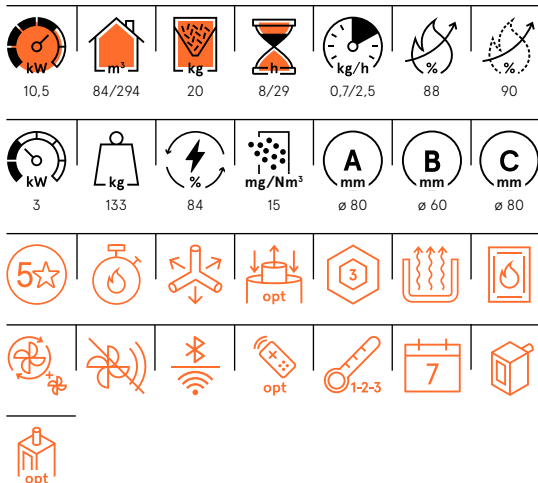

European standards
Art. 15A B-VG 2015
BImSchV 2015
Regensburg

München
Stuttgart
Aachen
EN 16510:2022

CE
Certificate model name:
ECLIPSE PLUS 11 T1



Atena Plus 12

● 12 kW

P. 72



Scopri le **caratteristiche** e il risparmio del **conto termico**

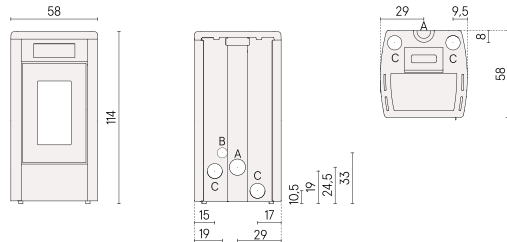

Ivory Majolica	Red Majolica	White Steel
Red Steel	Titanium Steel	Anthracite Steel

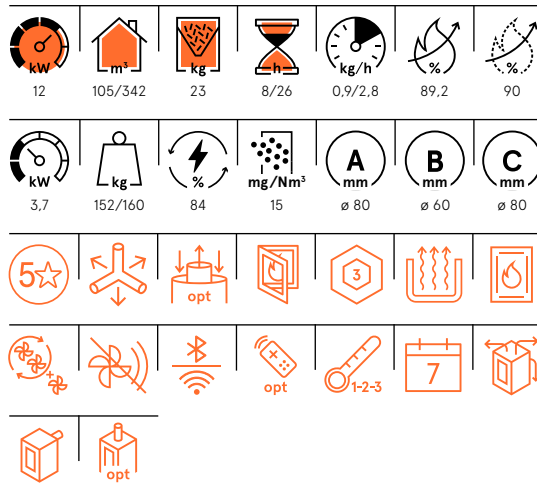

European standards
Art. 15A B-VG 2015
BImSchV 2015
Regensburg

München
Stuttgart
Aachen
EN 16510:2022

CE
Certificate model name:
ATENA PLUS 12 T2



Atena Plus 14

● 13,7 kW
P. 72



Scopri le **caratteristiche** e il risparmio del **conto termico**

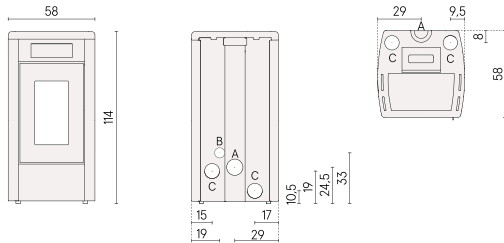

Ivory Majolica	Red Majolica	White Steel
Red Steel	Titanium Steel	Anthraccite Steel

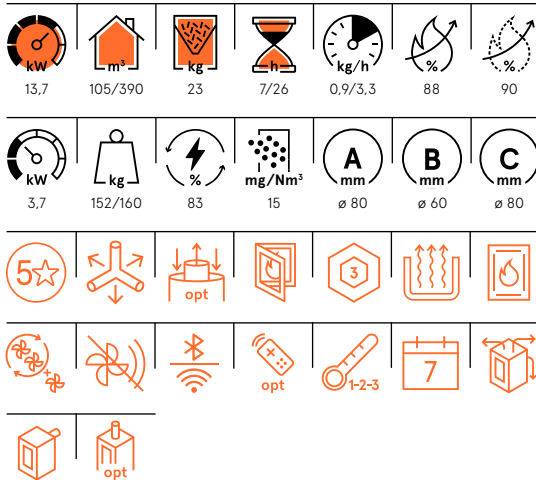

European standards
Art. 15A B-VG 2015
BImSchV 2015
Regensburg

München
Stuttgart
Aachen
EN 16510:2022



Certificate model name:
ATENA PLUS 14 T2



Mithos Plus 12 Ps

● 12 kW
P. 74



Scopri le **caratteristiche** e il risparmio del **conto termico**

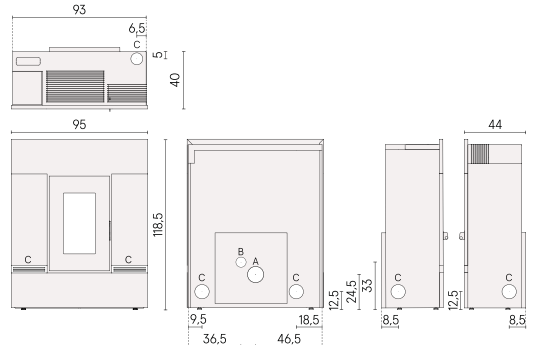

White Steel	Light Bronze Steel	Titanium Steel
Red Steel	Anthraccite Steel	Serpentino Stone

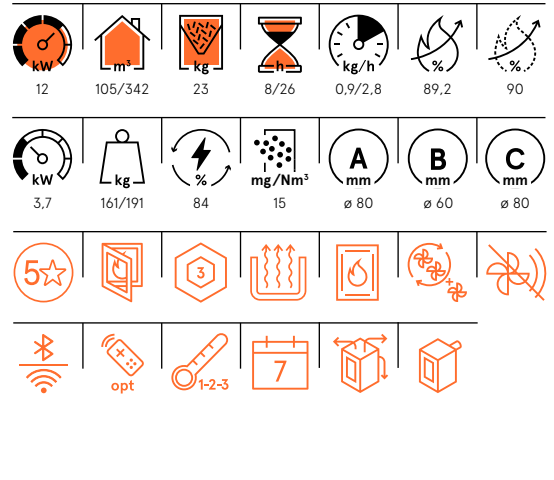

European standards
Art. 15A B-VG 2015
BImSchV 2015
Regensburg

München
Stuttgart
Aachen
EN 16510:2022



Certificate model name:
MITHOS PLUS 12 PS T2



Mithos Plus 14 Ps

● 13,7 kW

P. 74



Scopri le **caratteristiche** e il risparmio del **conto termico**

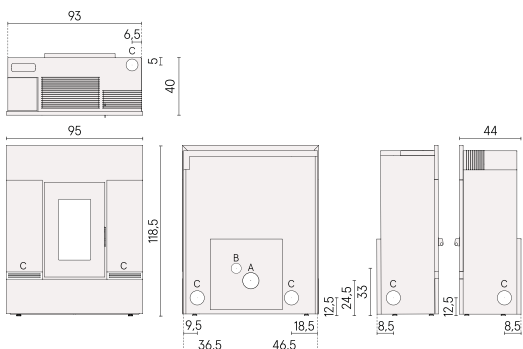
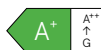

White Steel	Light Bronze Steel	Titanium Steel
Red Steel	Anthracite Steel	Serpentino Stone

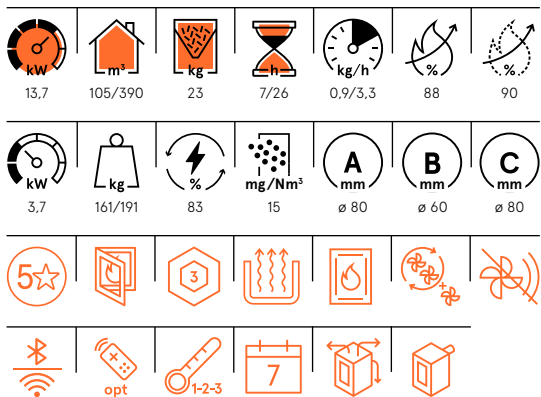

European standards
Art. 15A B-VG 2015
BimSchV 2015
Regensburg

München
Stuttgart
Aachen
EN 16510:2022

CE
Certificate model name:
MITHOS PLUS 14 PS T2



Mithos Plus 12 Up-Twin

● 12 kW

P. 74



Scopri le **caratteristiche** e il risparmio del **conto termico**

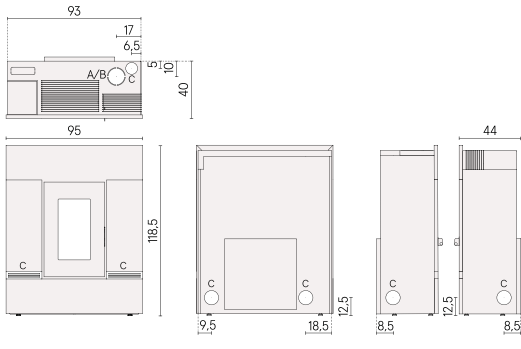

White Steel	Light Bronze Steel	Titanium Steel
Red Steel	Anthracite Steel	Serpentino Stone

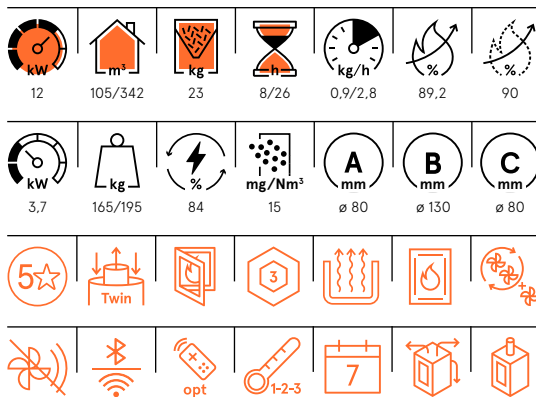

European standards
Art. 15A B-VG 2015
BimSchV 2015
Regensburg

München
Stuttgart
Aachen
EN 16510:2022

CE
Certificate model name:
MITHOS PLUS 12
UP-TWIN T2



Mithos Plus 14 Up-Twin

● 13,7 kW

P. 74



Scopri le **caratteristiche** e il risparmio del **conto termico**

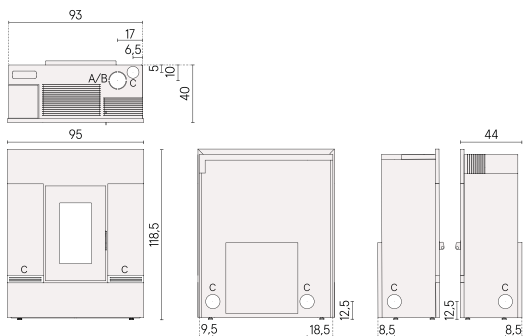
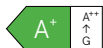

White Steel	Light Bronze Steel	Titanium Steel
Red Steel	Anthracite Steel	Serpentino Stone

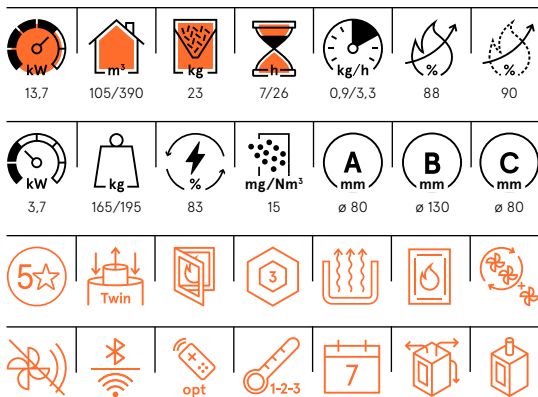

European standards
Art. 15A B-VG 2015
BImSchV 2015
Regensburg

München
Stuttgart
Aachen
EN 16510:2022



Certificate model name:
MITHOS PLUS 14
UP-TWIN T2



Pellet Hydro

La soluzione ideale per chi vuole scaldare anche i termosifoni e raggiungere un calore confortevole ed uniforme in tutta la casa

The ideal solution for customers who also want to heat radiators and enjoy a cosy temperature with evenly distributed heat throughout the house

La solution idéale pour chauffer aussi les radiateurs et obtenir une chaleur confortable et uniforme dans toute la maison

Die ideale Lösung, wenn auch die Heizkörper beheizt werden sollen und im gesamten Haus eine komfortable, gleichmäßige Wärme gewünscht ist

River Idro 18 Idrotech

● 17,7 kW

P. 76



Scopri le caratteristiche e il risparmio del conto termico

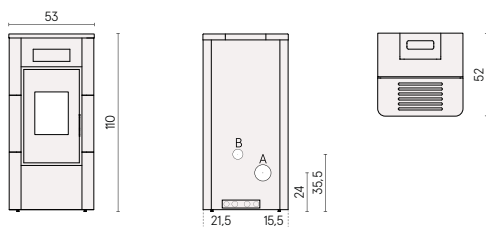
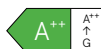

White Steel	Light Bronze Steel	Titanium Steel	Anthracite Steel
Red Majolica	White Majolica	Ivory Majolica	

17,7	123/496	24	6/24	12,7	2,3	1/3,9
4,4	94,8	95,9	136/167	91	10	ø 80
B mm ø 50 mm	5★	Idrotech	3			

European standards
BImSchV 2015
Regensburg
München

Stuttgart
Aachen
EN 16510:2022

CE
Certificate model name:
RIVER IDROTECH 18 TI



River Idro 24 Idrotech

● 24,2 kW

P. 76



Scopri le **caratteristiche** e il risparmio del **conto termico**

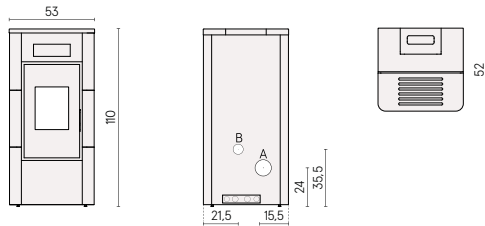

White Steel	Light Bronze Steel	Titanium Steel	Anthracite Steel
Red Majolica	White Majolica	Ivory Majolica	

24,2	123/678	24	4/24	18,2	2,3	1/5,4
4,4	92,9	95,9	136/167	89	12	ø 80
ø 50 mm						

European standards
BImSchV 2015
Regensburg
München

Stuttgart
Aachen
EN 16510:2022

CE
Certificate model name:
RIVER IDROTECH 24 T1



River Idro 16

● 16,1 kW

P. 78



Scopri le **caratteristiche** e il risparmio del **conto termico**

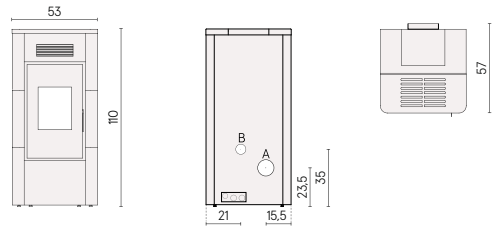

White Steel	Light Bronze Steel	Titanium Steel	Anthracite Steel
Red Majolica	White Majolica	Ivory Majolica	

16,1	137/451	22	6/22	12,9	3,4	1/3,6
4,9	93,7	96,7	136/167	89	13	ø 80
ø 50 mm						

European standards
BImSchV 2015
Regensburg
München

Stuttgart
Aachen
EN 16510:2022

CE
Certificate model name:
RIVER IDRO 16 T2



River Idro 23

● 22,4 kW

P. 78



Scopri le **caratteristiche** e il risparmio del **conto termico**

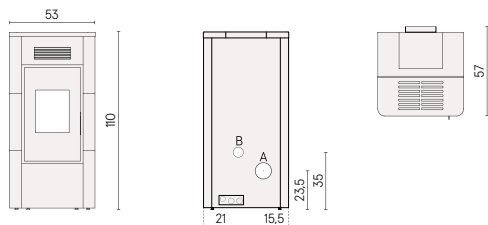
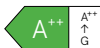

White Steel	Light Bronze Steel	Titanium Steel	Anthracite Steel
Red Majolica	White Majolica	Ivory Majolica	

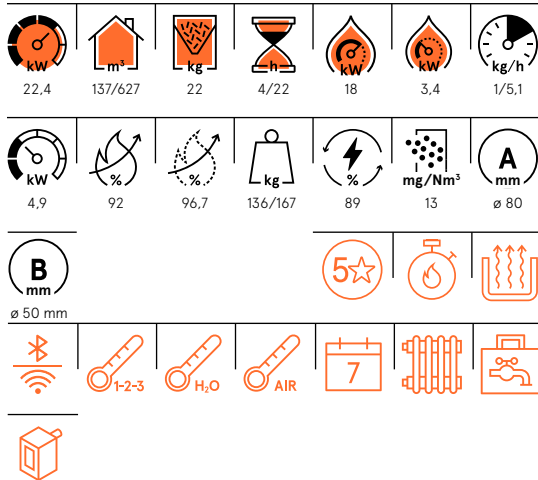

European standards
BImSchV 2015
Regensburg
München

Stuttgart
Aachen
EN 16510:2022



Certificate model name:
RIVER IDRO 23 T2



Saturno 16

● 18 kW

P. 80



Scopri le **caratteristiche** e il risparmio del **conto termico**

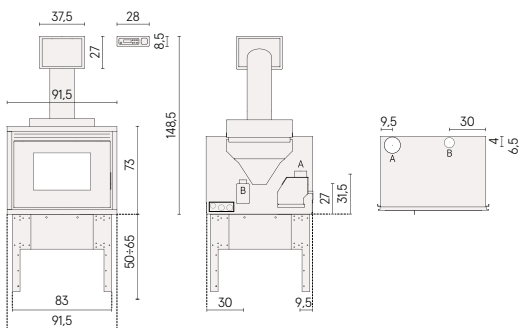
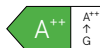

Black Steel

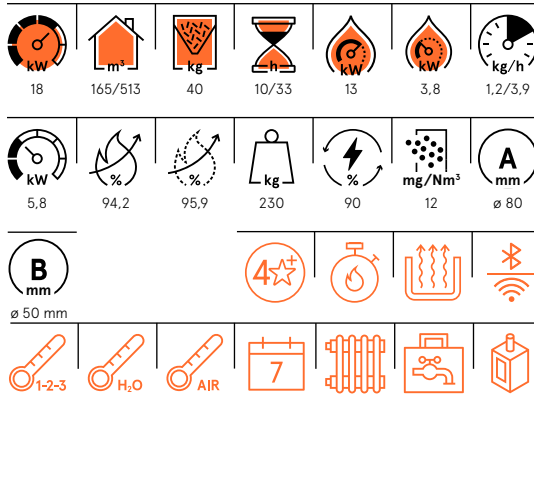

European standards
BImSchV 2015
Regensburg
München

Stuttgart
Aachen
EN 16510:2022



Certificate model name:
SATURNO 16



Saturno 24

● 24,7 kW

P. 80



Scopri le **caratteristiche** e il risparmio del **conto termico**

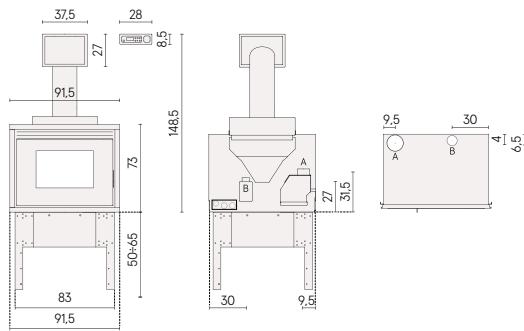

Black Steel

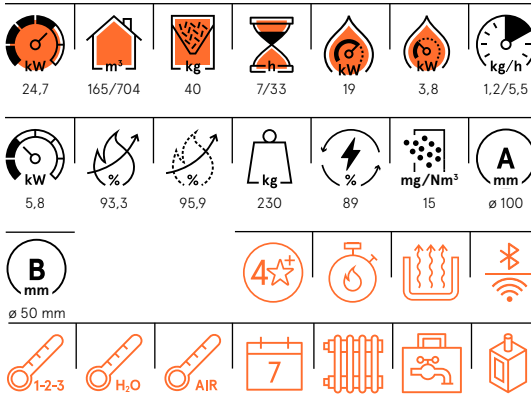

European standards
BImSchV 2015
Regensburg
München

Stuttgart
Aachen
EN 16510:2022

CE
Certificate model name:
SATURNO 24



Maya Idro 16

● 16,1 kW

P. 82



Scopri le **caratteristiche** e il risparmio del **conto termico**

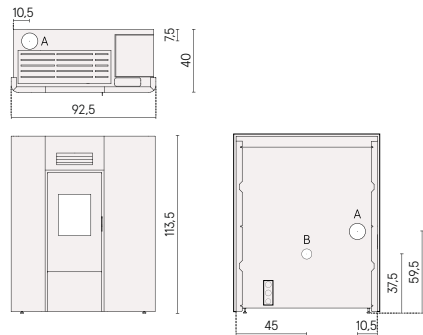

White Steel | **Light Bronze Steel** | **Titanium Steel**
Red Steel | **Anthracite Steel**

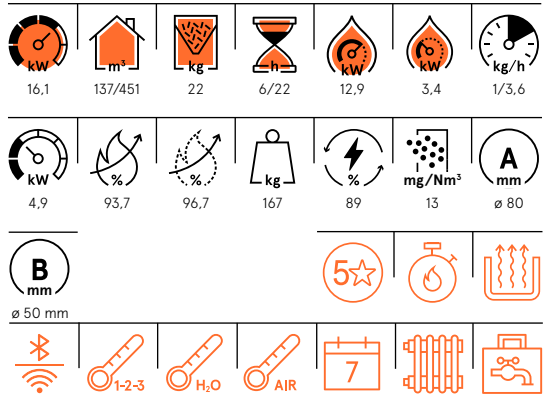

European standards
BImSchV 2015
Regensburg
München

Stuttgart
Aachen
EN 16510:2022

CE
Certificate model name:
MAYA IDRO 16 T2



Maya Idro 24

● 22,4 kW

P. 82



Scopri le **caratteristiche** e il risparmio del **conto termico**

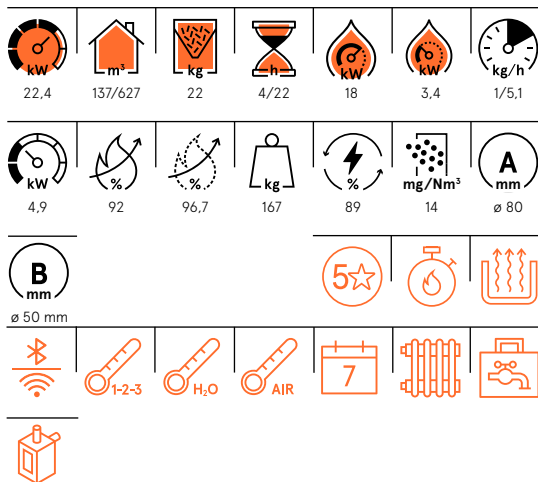
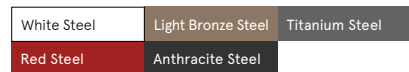
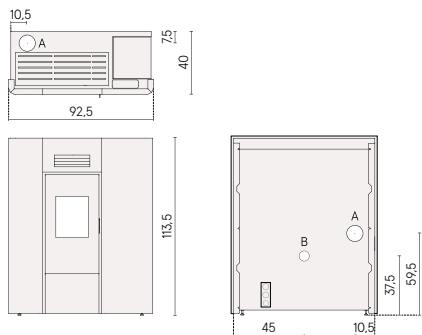
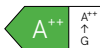

European standards
BImSchV 2015
Regensburg
München

Stuttgart
Aachen
EN 16510:2022

CE
Certificate model name:
MAYA IDRO 24 T2



Wood

Cucine economiche a legna a libera installazione e da incasso caratterizzate per unire il calore alla cottura

Free-standing and recessed wood-burning stoves that combine heat and cooking in one

Des cuisinières à bois à prix réduits, encastrables ou en pose libre pour cuisiner et chauffer en même temps

Holzherde, freistehend oder zum Einbau:
Heizen und Kochen in einem

Hublot 7 Wood/Wood Air

● 7 kW

P. /984

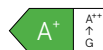

Scopri le caratteristiche e il risparmio del conto termico

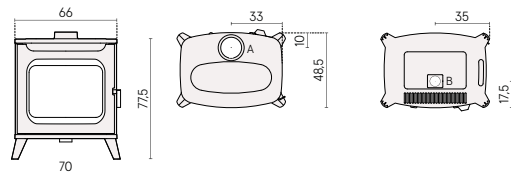

Cast Iron and Black Steel

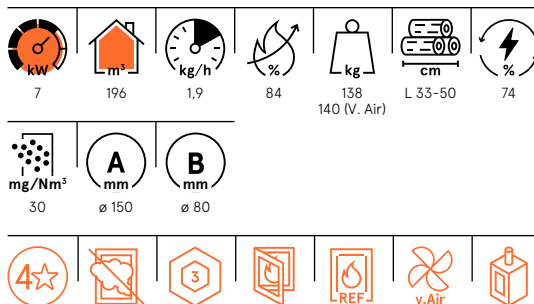

European standards Art. 15A B-VG 2015 BImSchV 2015 Regensburg München Stuttgart Aachen EN 16510:2022

CE Certificate model name: HUBLOT 7 WOOD T1 HUBLOT 7 WOOD - AIR T1



Hublot 8 Wood Air

● 7,5 kW

P. 84



Scopri le caratteristiche e il risparmio del conto termico

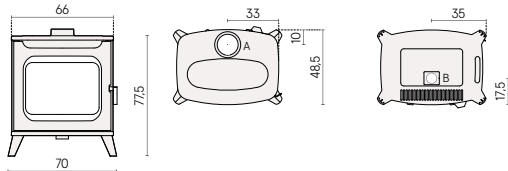

Cast Iron and Black Steel

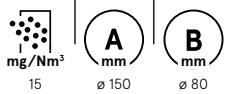
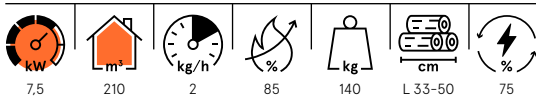

European standards
Art. 15A B-VG 2015
BImSchV 2015
Regensburg

München
Stuttgart
Aachen
EN 16510:2022



Certificate model name:
HUBLOT 8 WOOD AIR T2



Spin 8 Wood/Wood Air

● 8 kW

P. 86



Scopri le caratteristiche e il risparmio del conto termico

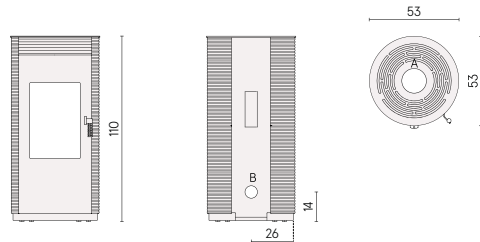

Black Cast Iron

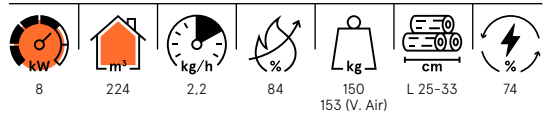

European standards
Art. 15A B-VG 2015
BImSchV 2015
Regensburg

München
Stuttgart
Aachen
EN 16510:2022



Certificate model name:
SPIN 8 WOOD T1
SPIN 8 WOOD AIR T1



Spin 9 Wood Air

● 9 kW
P. 86



Scopri le **caratteristiche** e il risparmio del **conto termico**

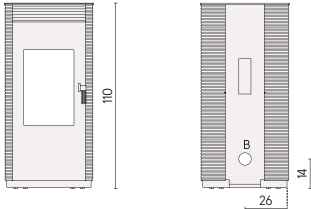

Black Cast Iron

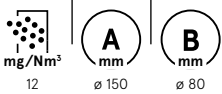

European standards
Art. 15A B-VG 2015
BImSchV 2015
Regensburg

München
Stuttgart
Aachen
EN 16510:2022



Certificate model name:
SPIN 9 WOOD AIR T2



Smart 60

● 6,5 kW
P. 88



Scopri le **caratteristiche** e il risparmio del **conto termico**

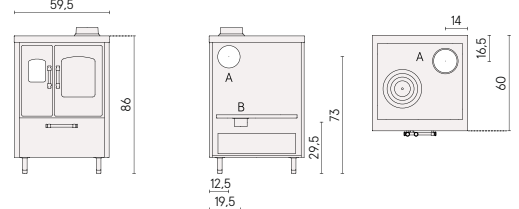

White Steel

Red Steel

Anthracite Steel

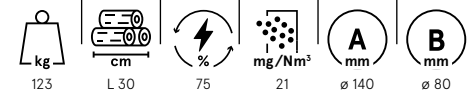
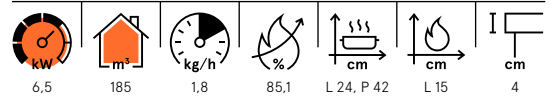

European standards
BImSchV 2015
Regensburg
München

Stuttgart
Aachen
EN 16510:2022



Certificate model name:
SMART 60, SMART 60V,
SMART 60S, SMART 60VS



Smart 80

● 7,5 kW

P. 88



Scopri le caratteristiche e il risparmio del conto termico

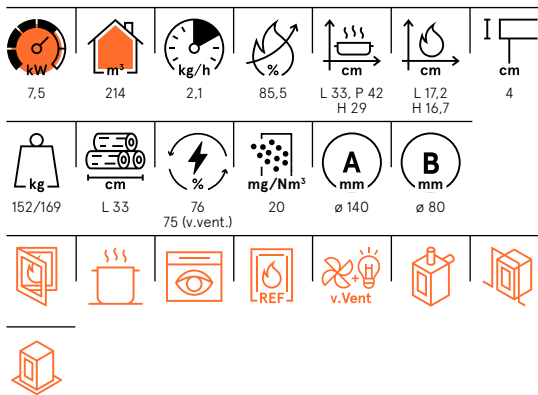
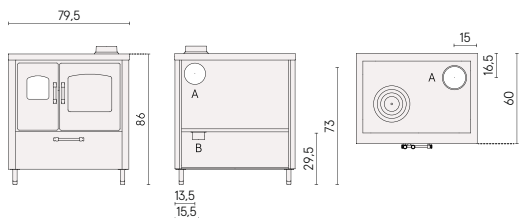
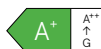

European standards
BimSchV 2015
Regensburg
München

Stuttgart
Aachen
EN 16510:2022

CE
Certificate model name:
SMART 80, SMART 80V,
SMART 80S, SMART 80VS



Kook 60

● 6,2 kW

P. 90



Scopri le caratteristiche del prodotto

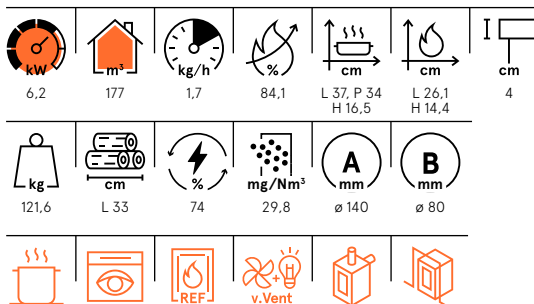
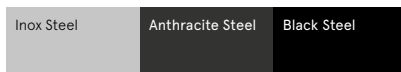
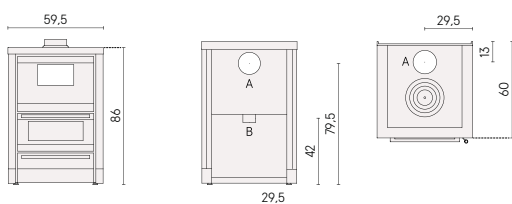
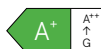

European standards Art.
15A B-VG 2015
BimSchV 2015
Regensburg
München

Stuttgart
Aachen
EN 16510:2022

CE
Certificate model name:
KOOK60 4.0,
KOOK60 4.0V



Kook 80

● 7,5 kW
P. 90



Scopri le
caratteristiche
del prodotto

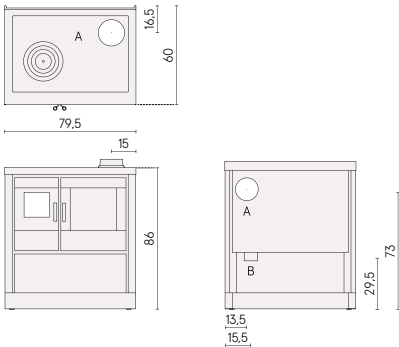

Inox Steel Anthracite Steel Black Steel

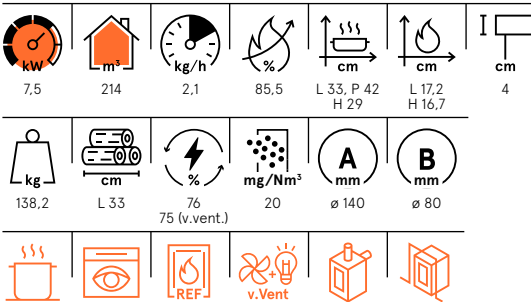

European standards
Art. 15A B-VG 2015
BlmSchV 2015
Regensburg
München

Stuttgart
Aachen
EN 16510:2022

CE
Certificate model name:
KOOK80, KOOK80V,
KOOK80S, KOOK80VS



Kook 90

● 7,5 kW
P. 90



Scopri le
caratteristiche
del prodotto

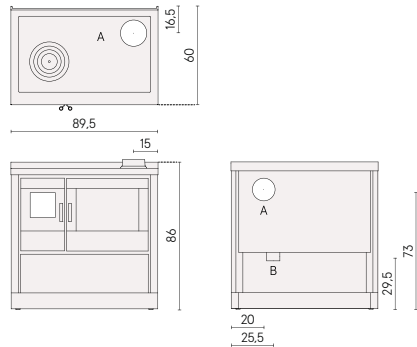

Inox Steel Anthracite Steel Black Steel

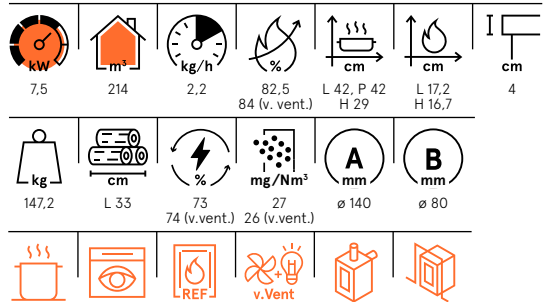

European standards Art.
15A B-VG 2015
BlmSchV 2015
Regensburg
München

Stuttgart
Aachen
EN 16510:2022

CE
Certificate model name:
KOOK90 4.0
KOOK90V 4.0



Blank page with horizontal dotted lines for writing.

Handwriting practice lines consisting of 25 horizontal dotted lines.



A series of horizontal dotted lines for writing, consisting of 25 lines spaced evenly down the page.

Graphic design
Metodo studio























Rendering
Alberto Rigo
e Metaverso

Printing
Imoco Group

Cadel S.r.l
Via Martiri della Libertà, 74
31025 Santa Lucia di Piave (TV)
Italy

cadelsrl.com

Technical data

	Potenza nominale Nominal power Puissance nominale Nennleistung		Potenza ridotta Reduced power Puissance réduite Verminderte Leistung
	Volume riscaldabile min/max Heatable volume min/max Volume à chauffer min/max Raumheizvermögen min/max		Capacità serbatoio Hopper capacity Capacité du réservoir Inhalt Pelletbehälter
	Potenza utile all'acqua nominale Nominal useful water power Puissance utile à l'eau nominale Nennwärmeleistung - Wasseranteil		Potenza utile all'acqua ridotta Reduced useful water power Puissance utile à l'eau réduite Min Nennwärmeleistung Wasseranteil
	Rendimento nominale Nominal performance Rendement nominal Wirkungsgrad bei Nennleistung		Rendimento ridotto Reduced performance Rendement réduit / Wirkungsgrad bei verminderter Leistung
	Consumo orario min/max Hourly consumption min/max Consommation horaire min/max Verbrauch pro Stunde		Autonomia min/max Range min/max Autonomie min/max Autonomie min/max
	Efficienza energetica stagionale (ETAs) Seasonal Energy Efficiency Efficacité énergétique saisonnière Raumheizungs-Jahresnutzungsgrad		Emissione polveri (13% O₂) Dust emission (13% O₂) Émission de poussières (13% O₂) Staubemission (13% O₂)
	Combustibile legna Wood fuel Combustible bois Brennstoff Holz		
	Scarico fumi Exhaust fumes Tuyau d'évacuation Rauchabzug		Presa aria comburente Hole combustion air inlet Prise d'air comburant Öffnungen für die Verbrennungsluft
			Uscita canalizzazione Ducting outlet Canalisation Kanalauslass
	Misure imballo Packing dimensions Mesures emballage Verpackung Ausmaße		Volume imballo Packing volume Volume emballage Verpackungsvolumen
			Peso netto Net weight Poids net Nettogewicht
	Misure forno Oven dimensions Mesures four Backofenmaße		Misure bocca fuoco Fire box dimensions Mesures entrée foyer Feuerstellemaße
	Altezza piano Cooktop height Hauteur plan de cuisson Kochfeldshöhe		



CADEL

cadel srl.com

cod. 87250012 07/2025